

# ABET LAMINATI - EASY MEG - PLANK SYSTEM HORIZONTAL APPLICATION

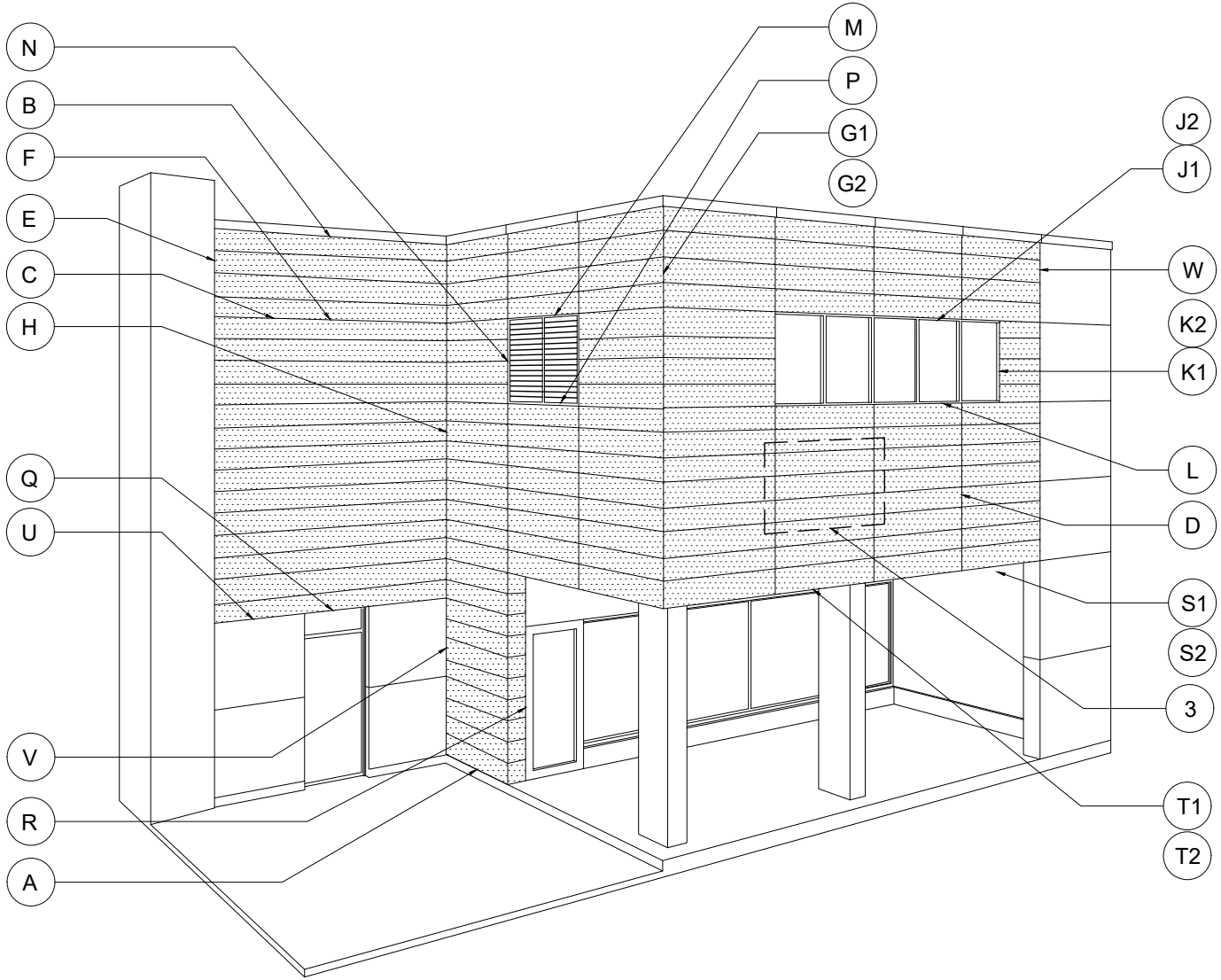

**EASYMEG**

**ABET LAMINATI**



STANDARD DETAIL CREATION

01/18/2023

REV.

ISSUANCE

DATE

DETAIL NAME:

DWG. BY: ACE

CHK. BY: ACE

PG. NO: OF 28

## LEGEND DETAILS

- ① 5/16" [8mm] THK., ABET EASY MEG PLANK
- |                                     |                                |
|-------------------------------------|--------------------------------|
| <u>Standard Sizes:</u>              | <u>Thickness Available:</u>    |
| * 8.189" x 120"<br>[208mm x 3050mm] | * 5/16" [8mm]<br>* 3/8" [10mm] |
- ② COUNTERSUNK FASTENERS:  
The clip can be screwed on any type of substrate:
- Aluminum
  - Steel
  - Wood
- The connection screw type will change depending on the substrate material
- WOOD: #8-15 x 1" SHARP POINT SCREW
- ALUMINUM: #8-18 x 1" SELF-DRILLING SCREW
- ③ EZCJC SUPPORT CLIP (6005-T5 ALUM. CLIP)
- ④ XZB & XHB & XEB SUBGIRT (6005-T5 Alum.)
- ⑤ SFS SX3-D16, COLOR MATCHED FASTENER
- ⑥ XB02 - PERFORATED SILL FLASHING (OPTIONAL)
- ⑦ WALL STRUCTURE/MATERIAL (BY OTHERS)
- ⑧ 1/8" SHIM (BY OTHERS)
- ⑨ INSULATION (BY OTHERS)
- ⑩ AIR/VAPOUR BARRIER (BY OTHERS)
- ⑪ SUBSTRATE (BY OTHERS)
- ⑫ STRUCTURAL FRAMING (BY OTHERS)
- ⑬ CONCRETE (BY OTHERS)
- ⑭ METAL TRIMS/FLASHING/CAP (BY OTHERS)
- ⑮ FASTENER (BY OTHERS)
- ⑯ WOOD FURRING (BY OTHERS)
- ⑰ EPDM GASKET (BY OTHERS)
- ⑱ FIXED POINT SET NAIL

## TABLE OF CONTENTS

<u>Page No:</u>	<u>Details:</u>
00	DETAIL LOCATOR
01	TABLE OF CONTENTS
02	PARTIAL PANEL ELEVATION (0)
03	BOTTOM TERMINATION (A)
04	TOP TERMINATION DETAIL (B)
05	HORIZONTAL JOINT DETAIL (C)
06	VERTICAL JOINT DETAIL (D)
07	VERTICAL TERMINATION DETAIL (E)
08	PLAN MIDDLE SUPPORT DETAIL (Fixed Point) (F)
09	OUTSIDE CORNER DETAIL (Option 1) (G1)
10	OUTSIDE CORNER DETAIL (Option 2) (G2)
11	VERTICAL INSIDE CORNER DETAIL (H)
12	WINDOW HEAD DETAIL (Option 1) (J1)
13	WINDOW HEAD DETAIL (Option 2) (J2)
14	WINDOW JAMB DETAIL (Option 1) (K1)
15	WINDOW JAMB DETAIL (Option 2) (K2)
16	WINDOW SILL DETAIL (L)
17	LOUVER HEAD DETAIL (M)
18	LOUVER JAMB DETAIL (N)
19	LOUVER SILL DETAIL (P)
20	H.M. DOOR HEAD DETAIL (Q)
21	H.M. DOOR JAMB DETAIL (R)
22	PANEL/SOFFIT TRANSITION DETAIL (1) (S1)
23	PANEL/SOFFIT TRANSITION DETAIL (2) (S2)
24	PANEL/FASCIA TRANSITION DETAIL (1) (T1)
25	PANEL/FASCIA TRANSITION DETAIL (2) (T2)
26	VERTICAL TRANSITION DETAIL (U)
27	VERTICAL TRANSITION DETAIL (V)
28	HORIZONTAL TRANSITION DETAIL (W)

**EASYMEG**

**ABET LAMINATI**



STANDARD DETAIL CREATION

01/18/2023

REV.

ISSUANCE

DATE

DETAIL NAME:

DWG. BY: ACE

CHK. BY: ACE

PG. NO: 1 OF 28

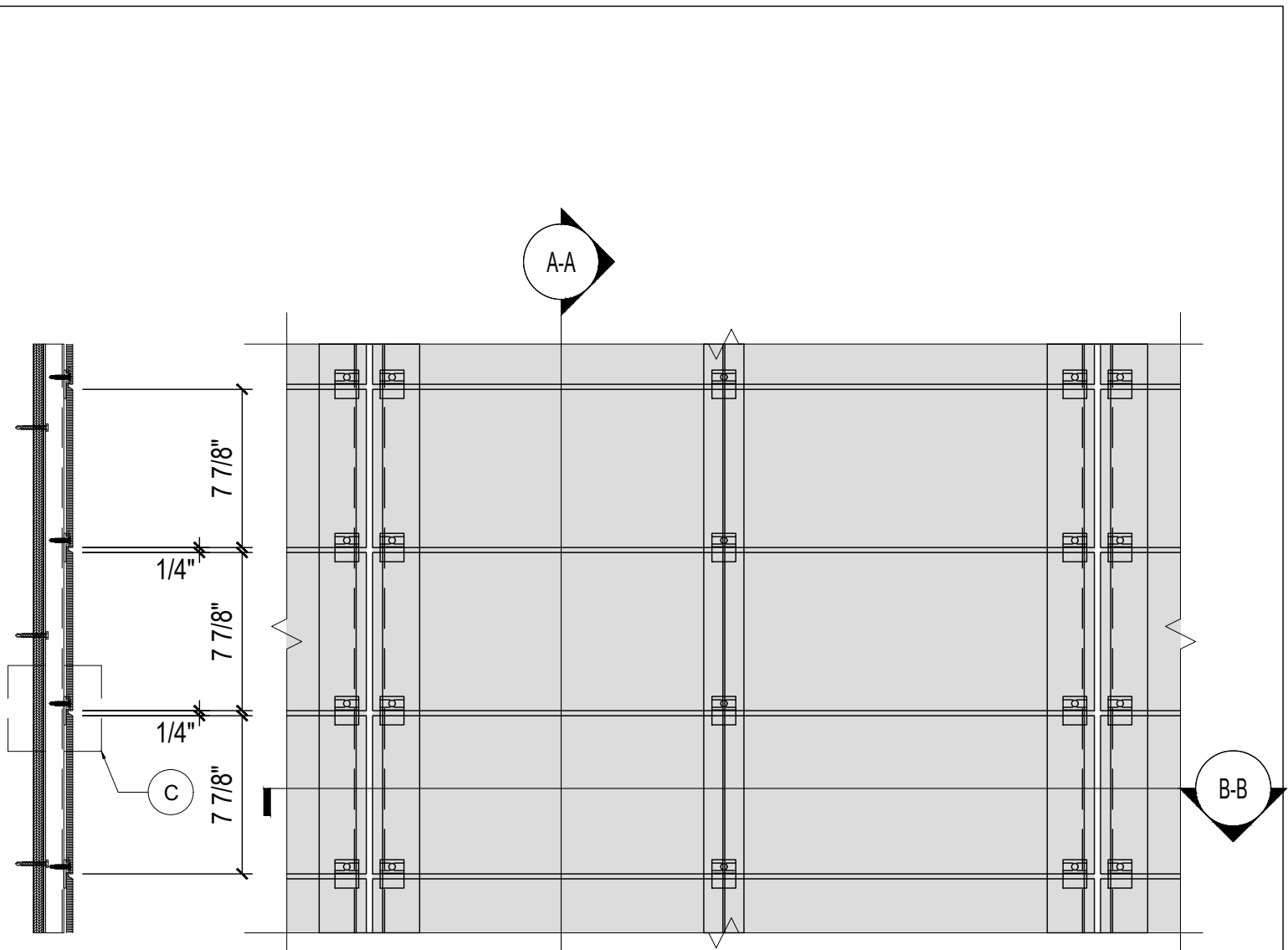

A-A

ELEVATION SEGMENT

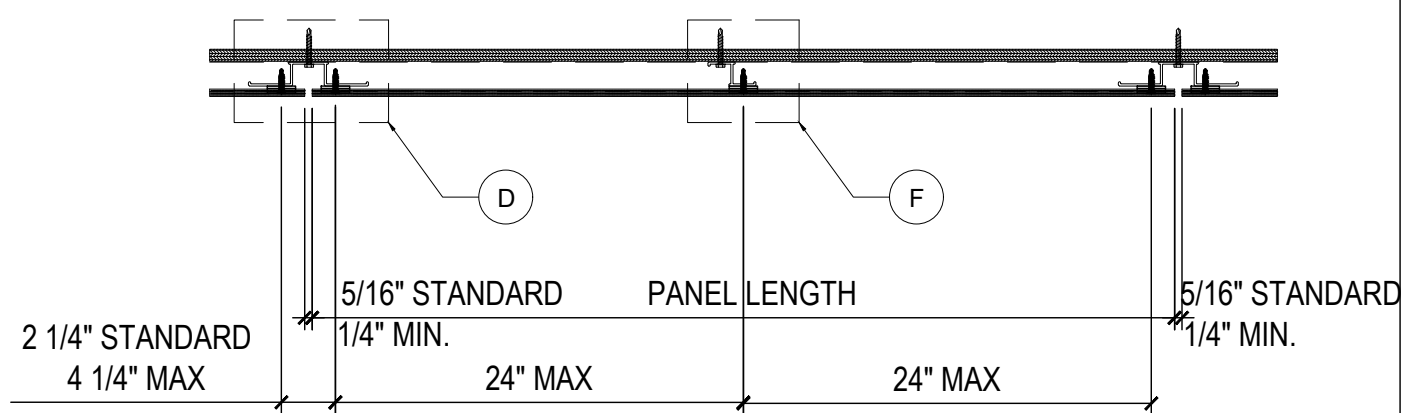

B-B

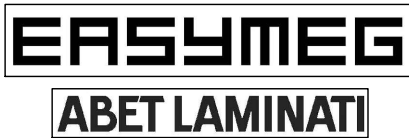

		DETAIL NAME: <b>ELEVATION SEGMENT HORIZONTAL APPLICATION</b>	
△	STANDARD DETAIL CREATION	01/18/2023	
REV.	ISSUANCE	DATE	DWG. BY: ACE    CHK. BY: ACE    PG. NO: 3 OF 28

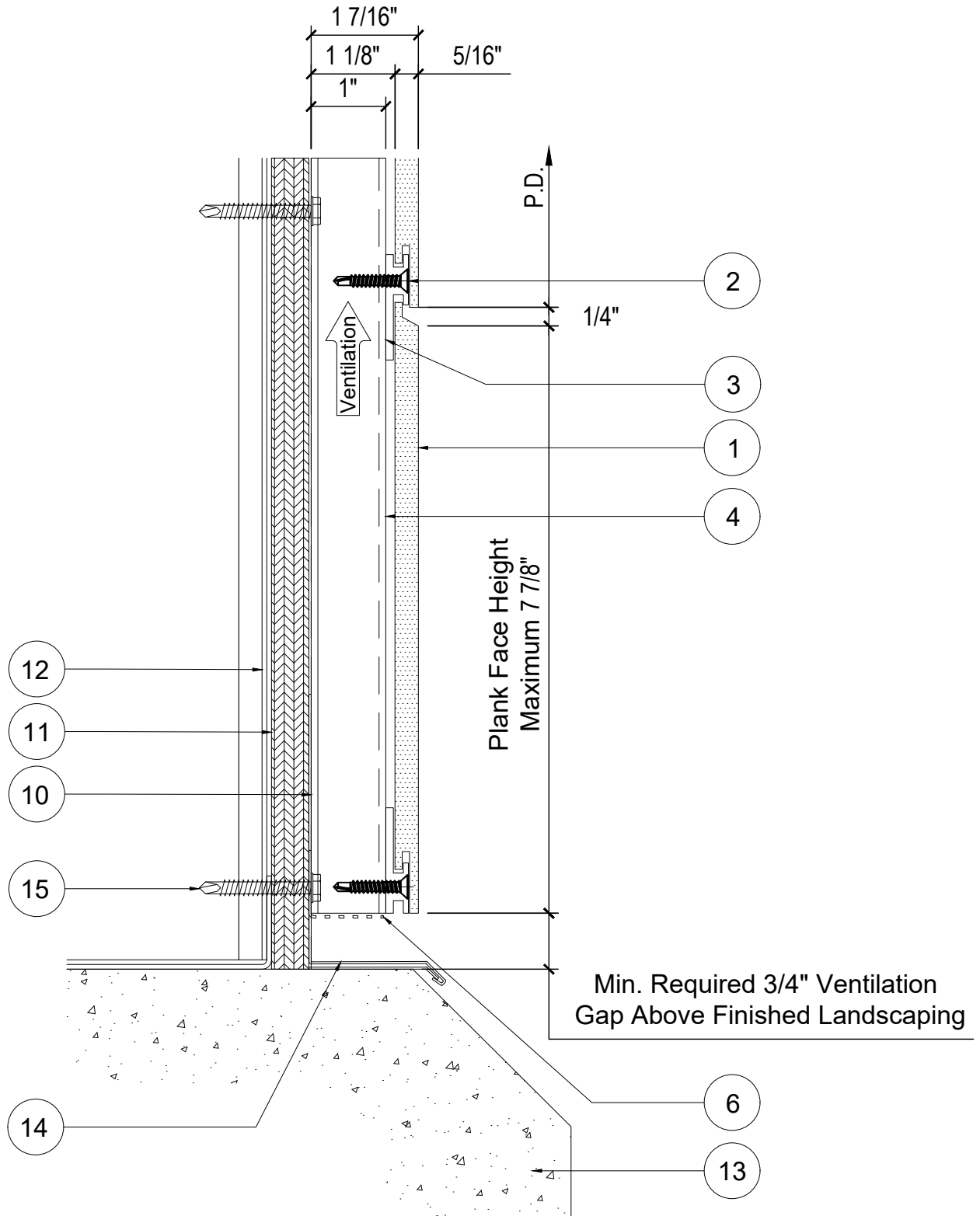

**EASYMEG**

**ABET LAMINATI**



STANDARD DETAIL CREATION

01/18/2023

REV.

ISSUANCE

DATE

DETAIL NAME:

**BOTTOM TERMINATION  
DETAIL (A)**

DWG. BY: ACE

CHK. BY: ACE

PG. NO: 3 OF 28

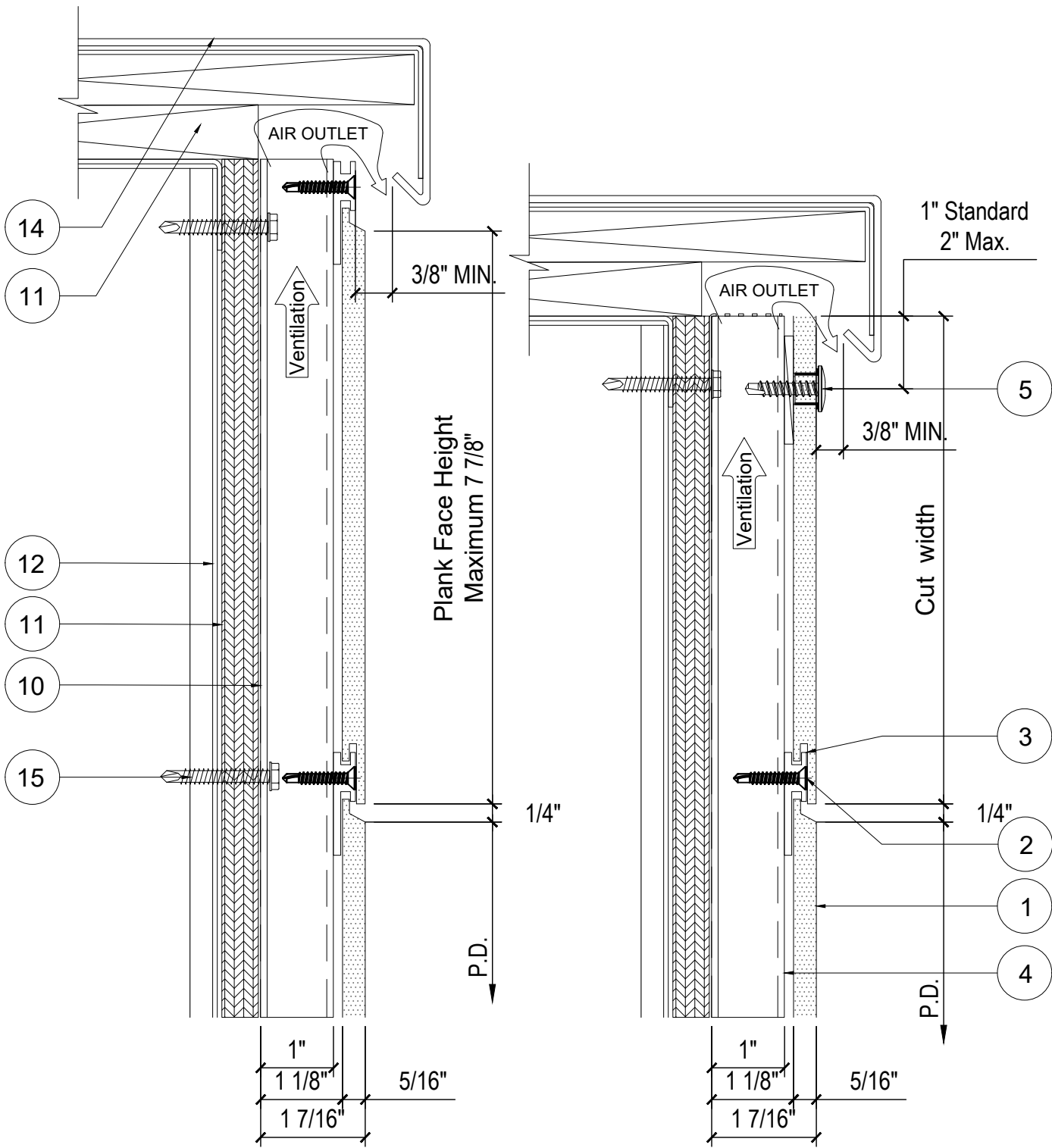

**EASYMEG**  
**ABET LAMINATI**



STANDARD DETAIL CREATION 01/18/2023

REV. ISSUANCE DATE

DETAIL NAME:  
**TOP TERMINATION  
 DETAIL (B)**

DWG. BY: ACE    CHK. BY: ACE    PG. NO: 4 OF 28

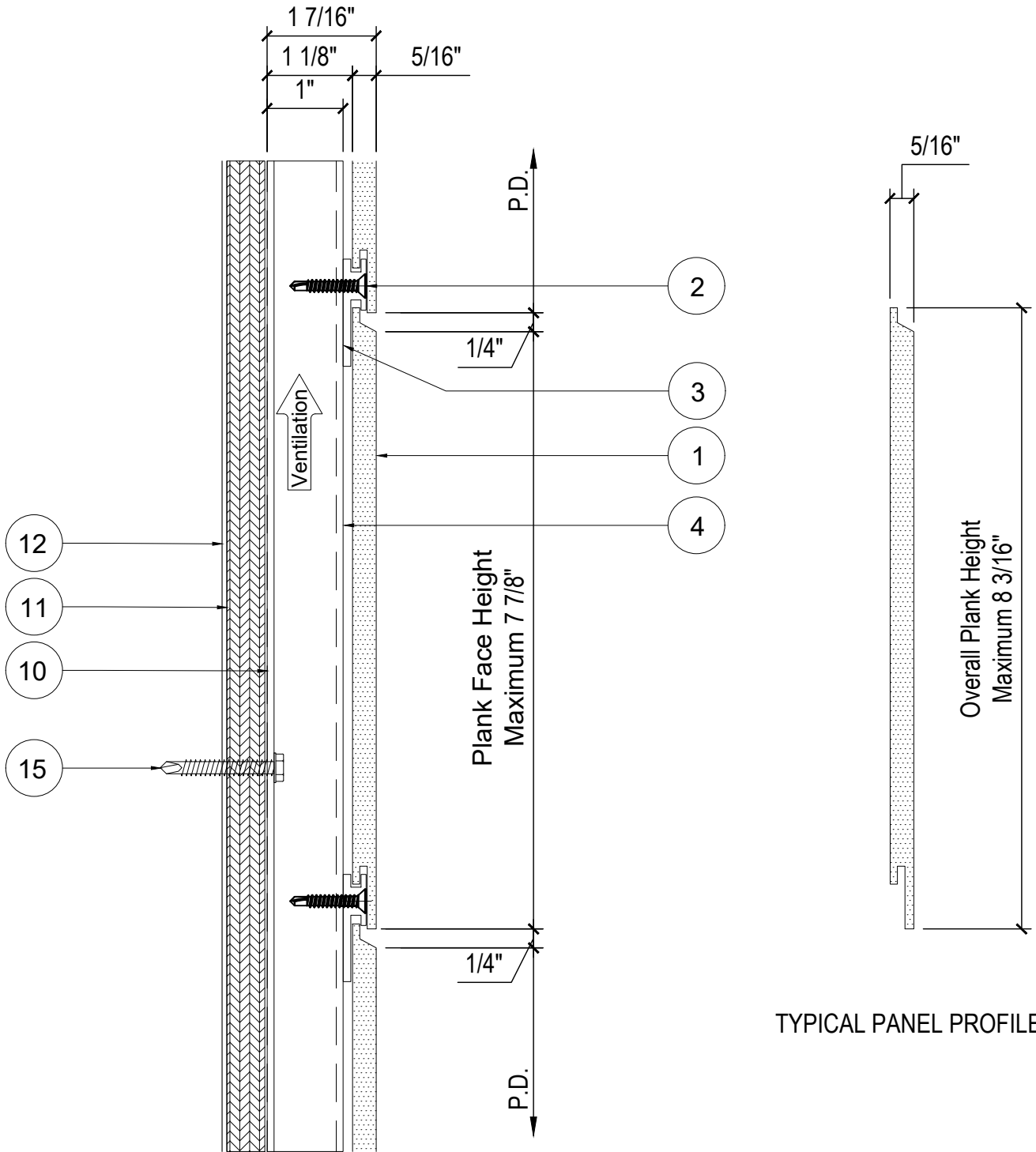

TYPICAL PANEL PROFILE



	STANDARD DETAIL CREATION	01/18/2023	DETAIL NAME: TYPICAL HORIZONTAL JOINT DETAIL (C)		
	ISSUANCE	DATE	DWG. BY: ACE	CHK. BY: ACE	PG. NO: 5 OF 28

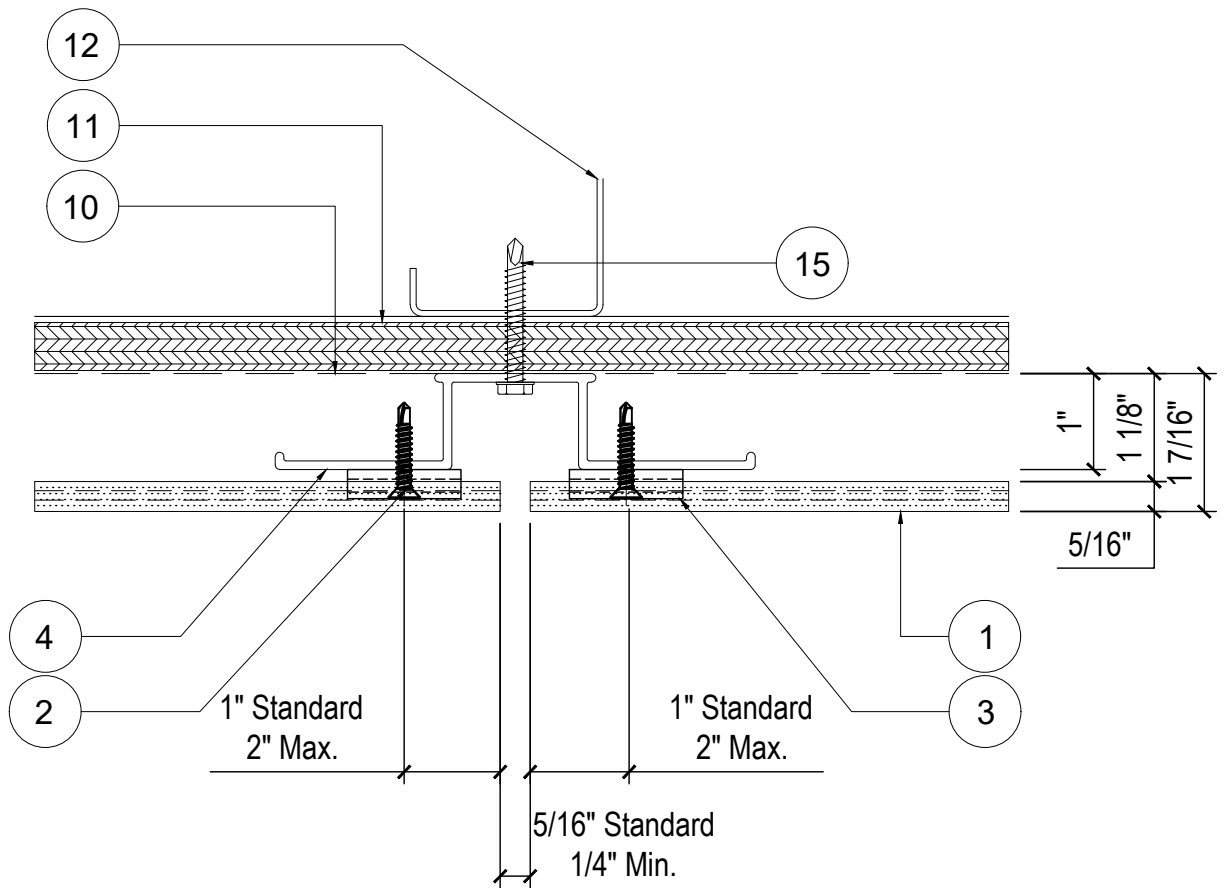

**EASYMEG**

**ABET LAMINATI**



STANDARD DETAIL CREATION

01/18/2023

REV.

ISSUANCE

DATE

DETAIL NAME:

**TYPICAL VERTICAL  
JOINT DETAIL (D)**

DWG. BY: ACE

CHK. BY: ACE

PG. NO: 6 OF 28

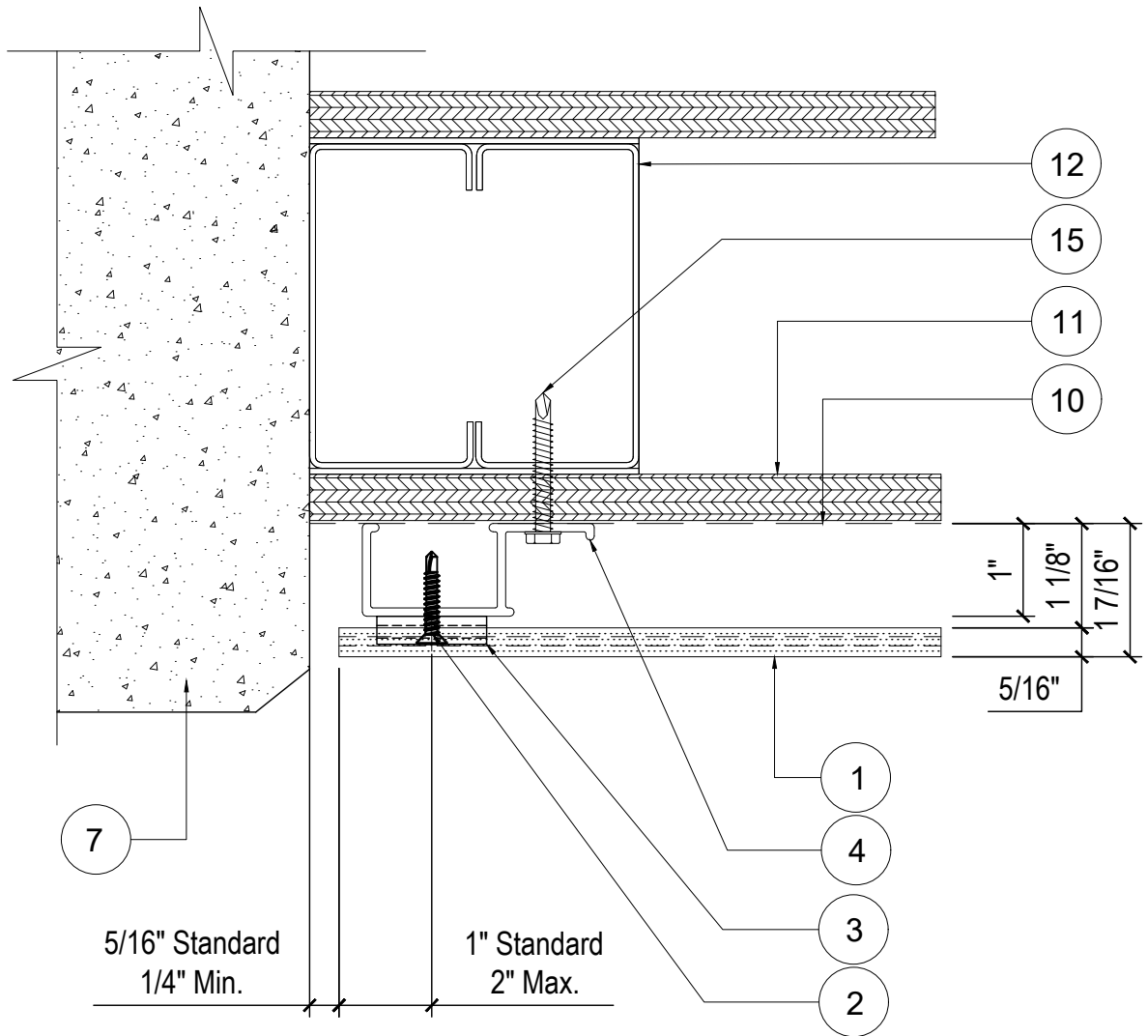

**EASYMEG**

**ABET LAMINATI**



STANDARD DETAIL CREATION

01/18/2023

REV.

ISSUANCE

DATE

DETAIL NAME:

**VERTICAL TERMINATION  
DETAIL (E)**

DWG. BY: ACE

CHK. BY: ACE

PG. NO: 7 OF 28



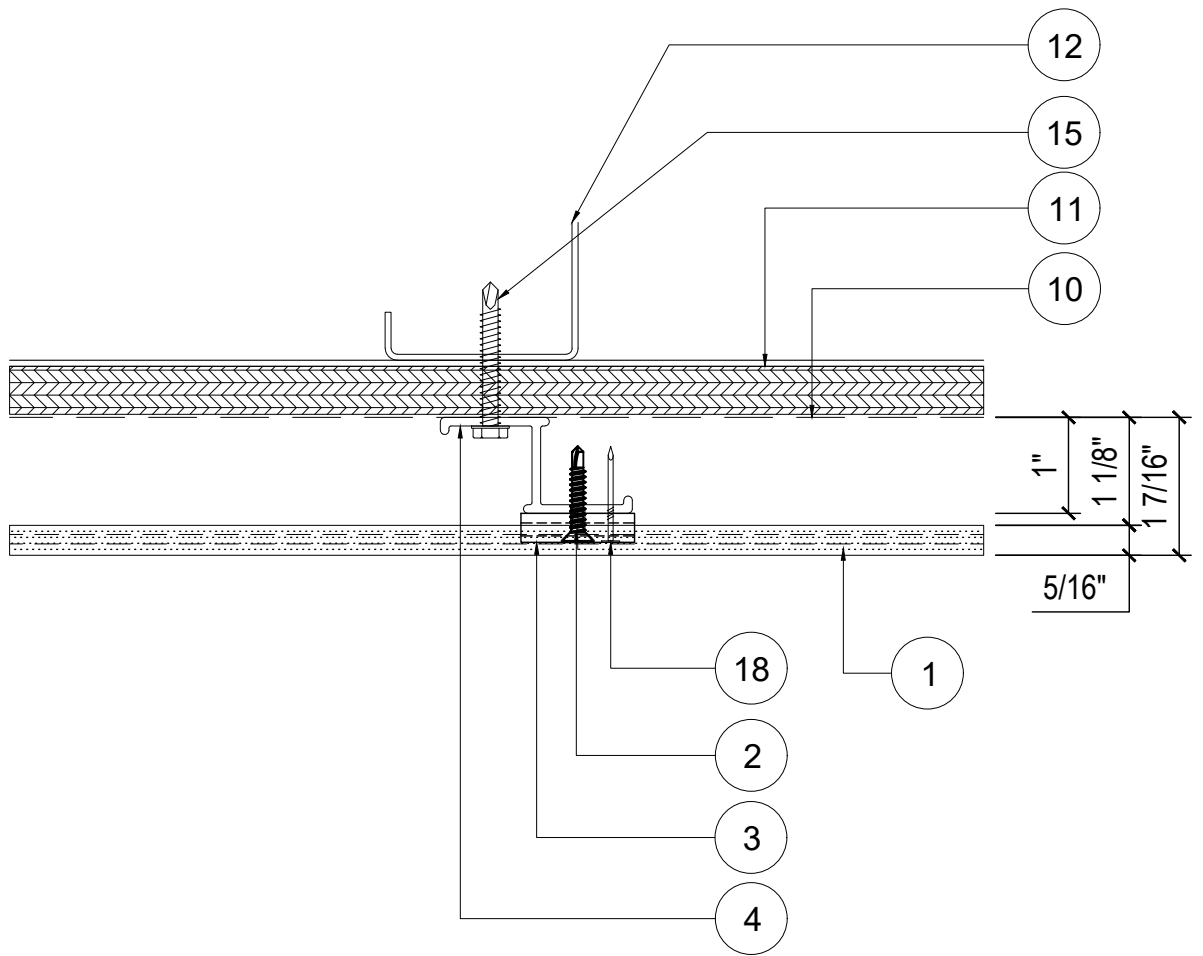

**EASYMEG**

**ABET LAMINATI**



STANDARD DETAIL CREATION

01/18/2023

REV.

ISSUANCE

DATE

DETAIL NAME:

PLAN MIDDLE SUPPORT  
DETAIL (FIXED POINT) (F)

DWG. BY: ACE

CHK. BY: ACE

PG. NO: 8 OF 28

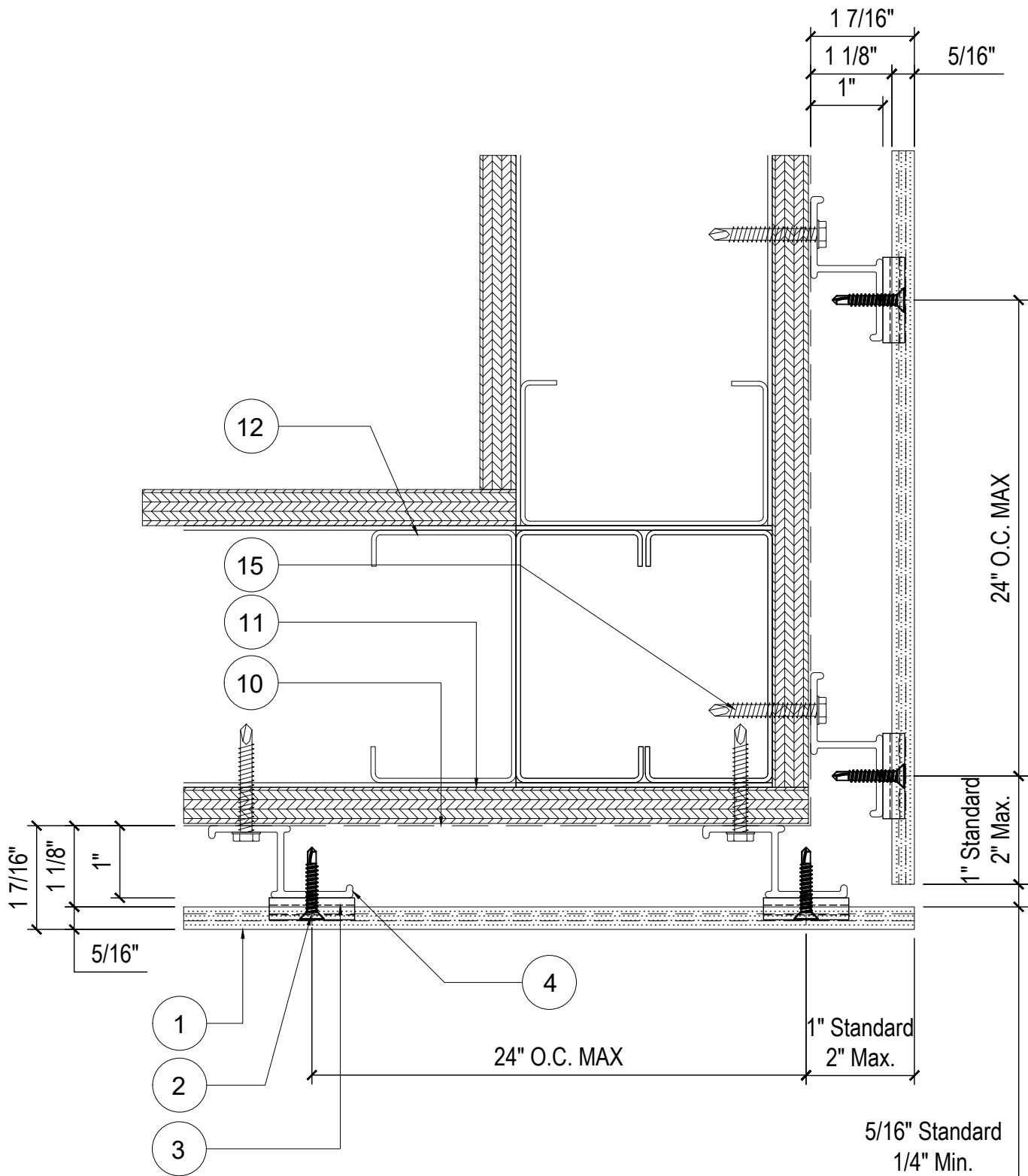

**EASYMEG**

**ABET LAMINATI**



STANDARD DETAIL CREATION

01/18/2023

REV.

ISSUANCE

DATE

DETAIL NAME:

**VERTICAL OUTSIDE  
CORNER DETAIL (G1)**

DWG. BY: ACE

CHK. BY: ACE

PG. NO: 9 OF 28

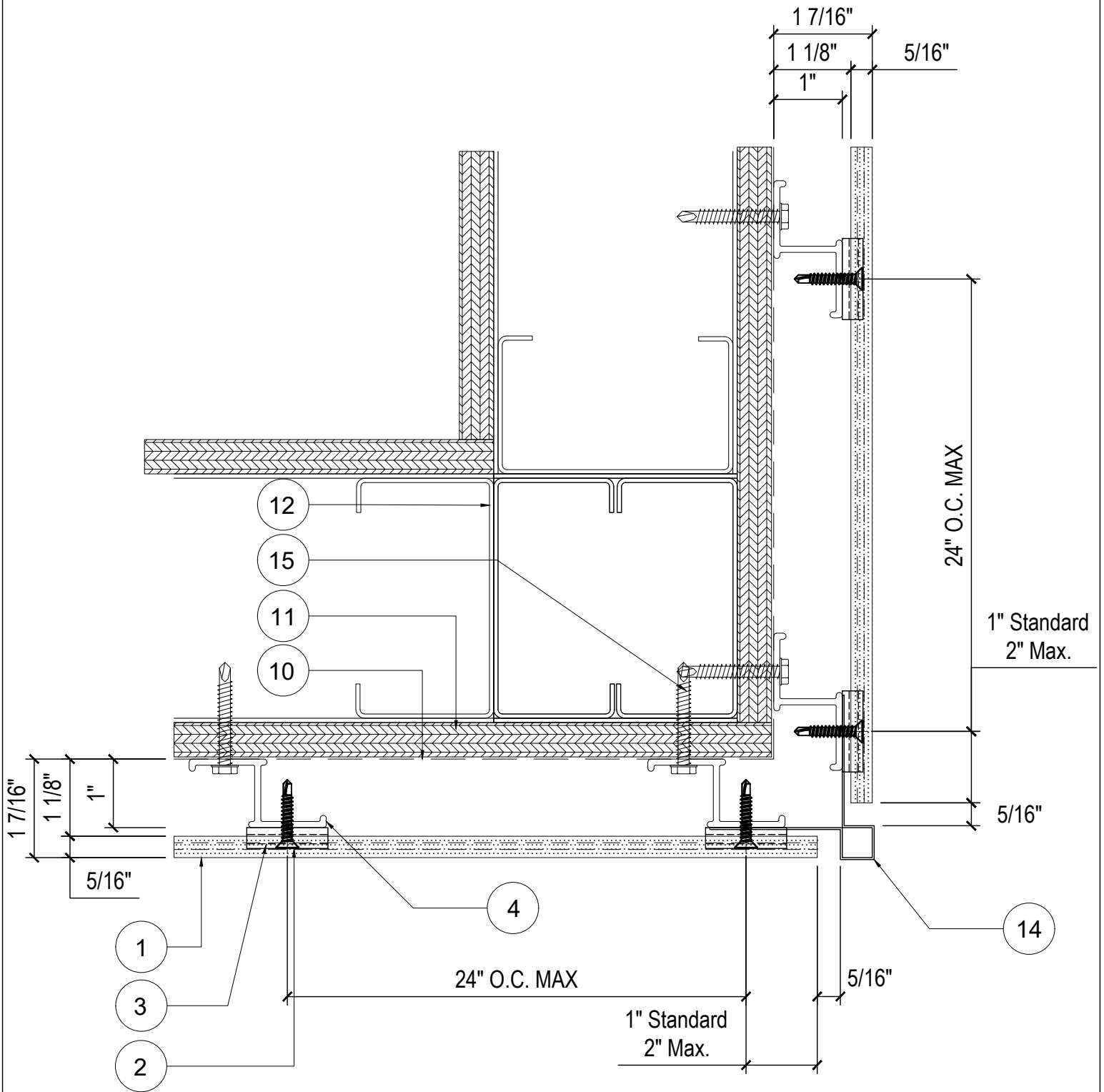

**EASYMEG**

**ABET LAMINATI**



REV.

STANDARD DETAIL CREATION

ISSUANCE

01/18/2023

DATE

DETAIL NAME:

**VERTICAL OUTSIDE  
CORNER DETAIL G2)**

DWG. BY: ACE

CHK. BY: ACE

PG. NO: 10 OF 28

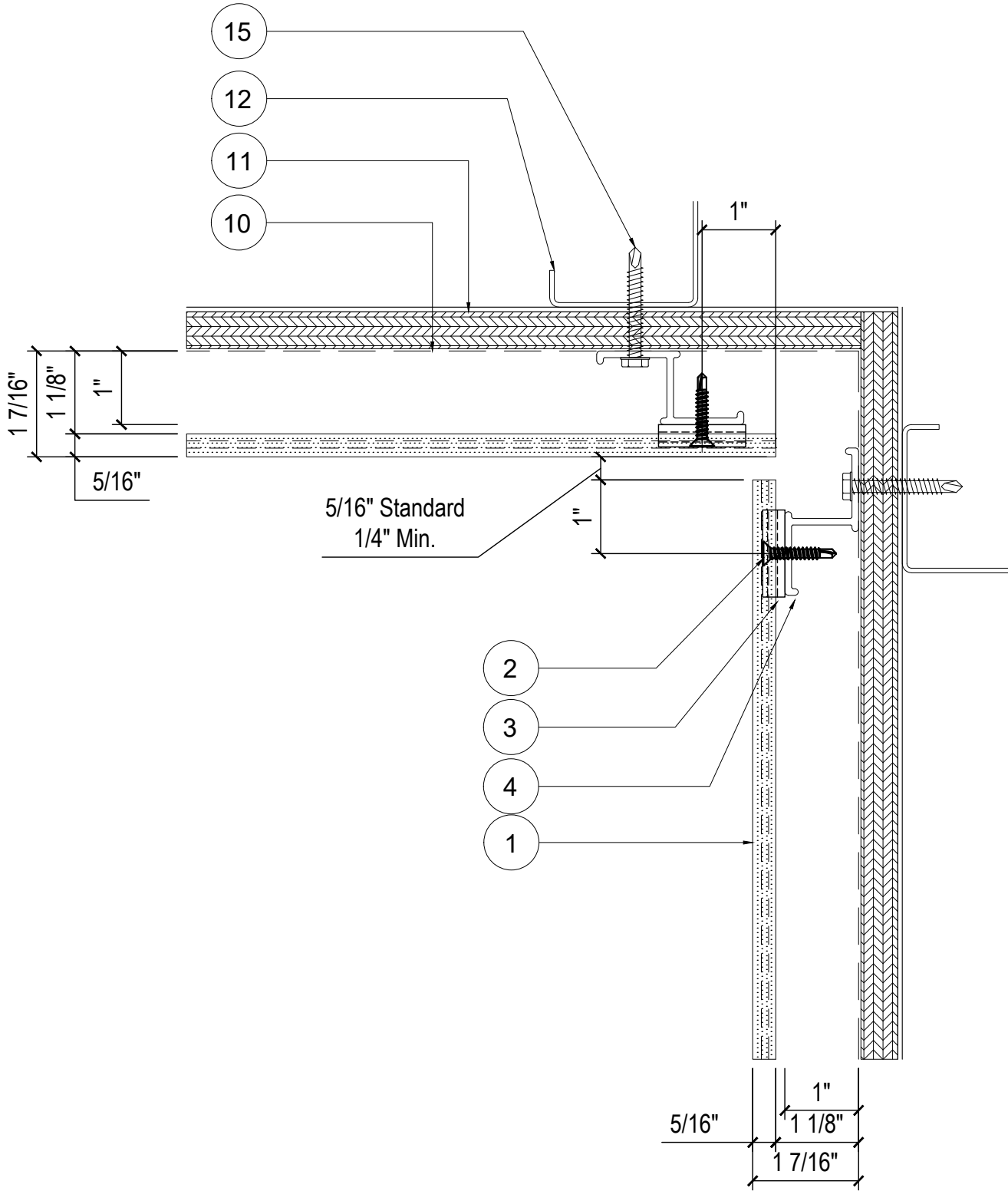

**EASYMEG**

**ABET LAMINATI**



STANDARD DETAIL CREATION

01/18/2023

REV.

ISSUANCE

DATE

DETAIL NAME:

**VERTICAL INSIDE  
CORNER DETAIL (H)**

DWG. BY: ACE

CHK. BY: ACE

PG. NO: 11 OF 28

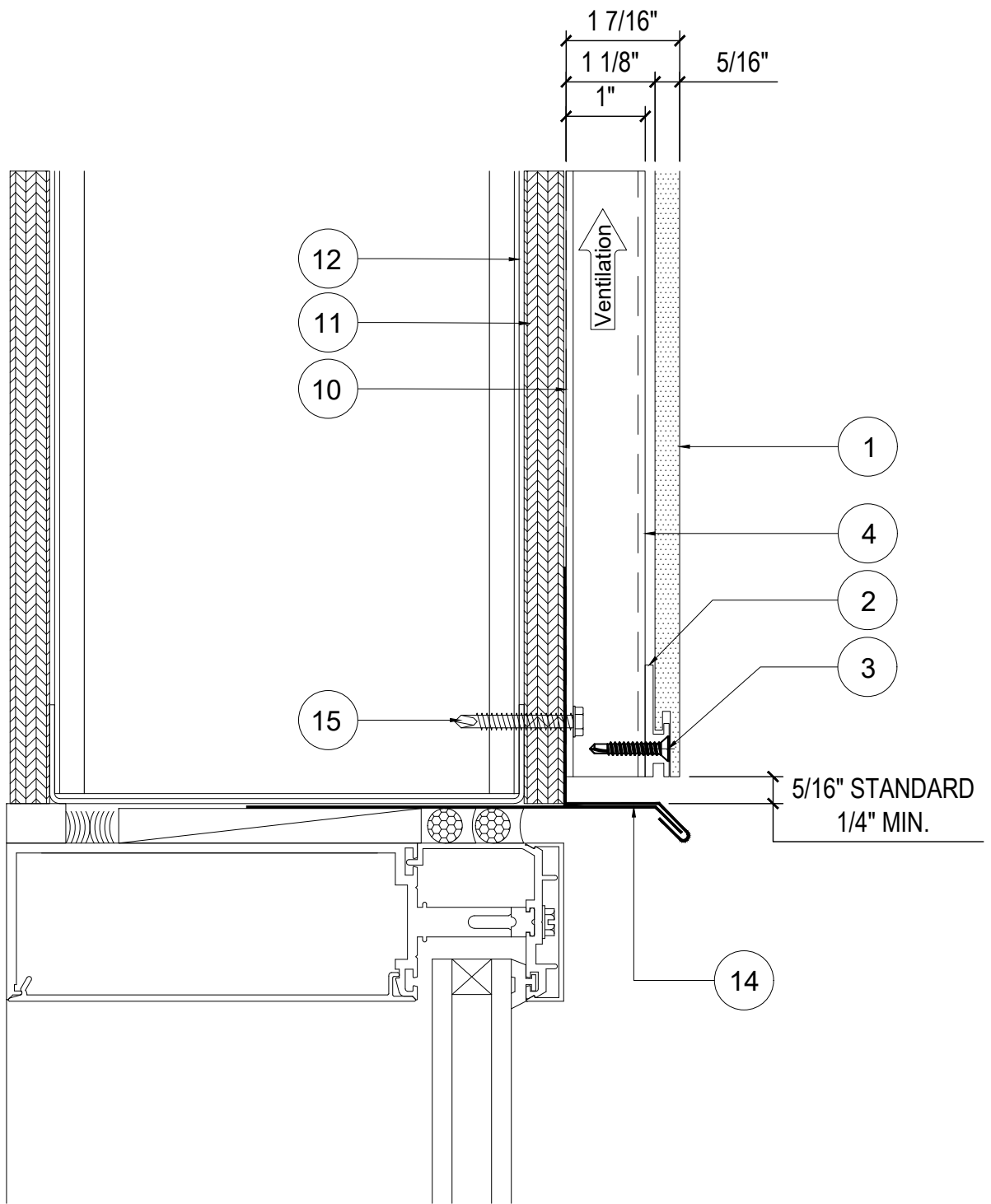

**EASYMEG**

**ABET LAMINATI**



STANDARD DETAIL CREATION

01/18/2023

REV.

ISSUANCE

DATE

DETAIL NAME:

WINDOW HEAD  
DETAIL (J1)

DWG. BY: ACE

CHK. BY: ACE

PG. NO: 12 OF 28

MIN LENGTH = 2 1/2" - 2" TO ALLOW FOR COVERAGE OF CLIP + 1/4" OVERAGE ON EACH SIDE  
 PANEL LENGTH > 4" 2 CLIPS ARE REQUIRED

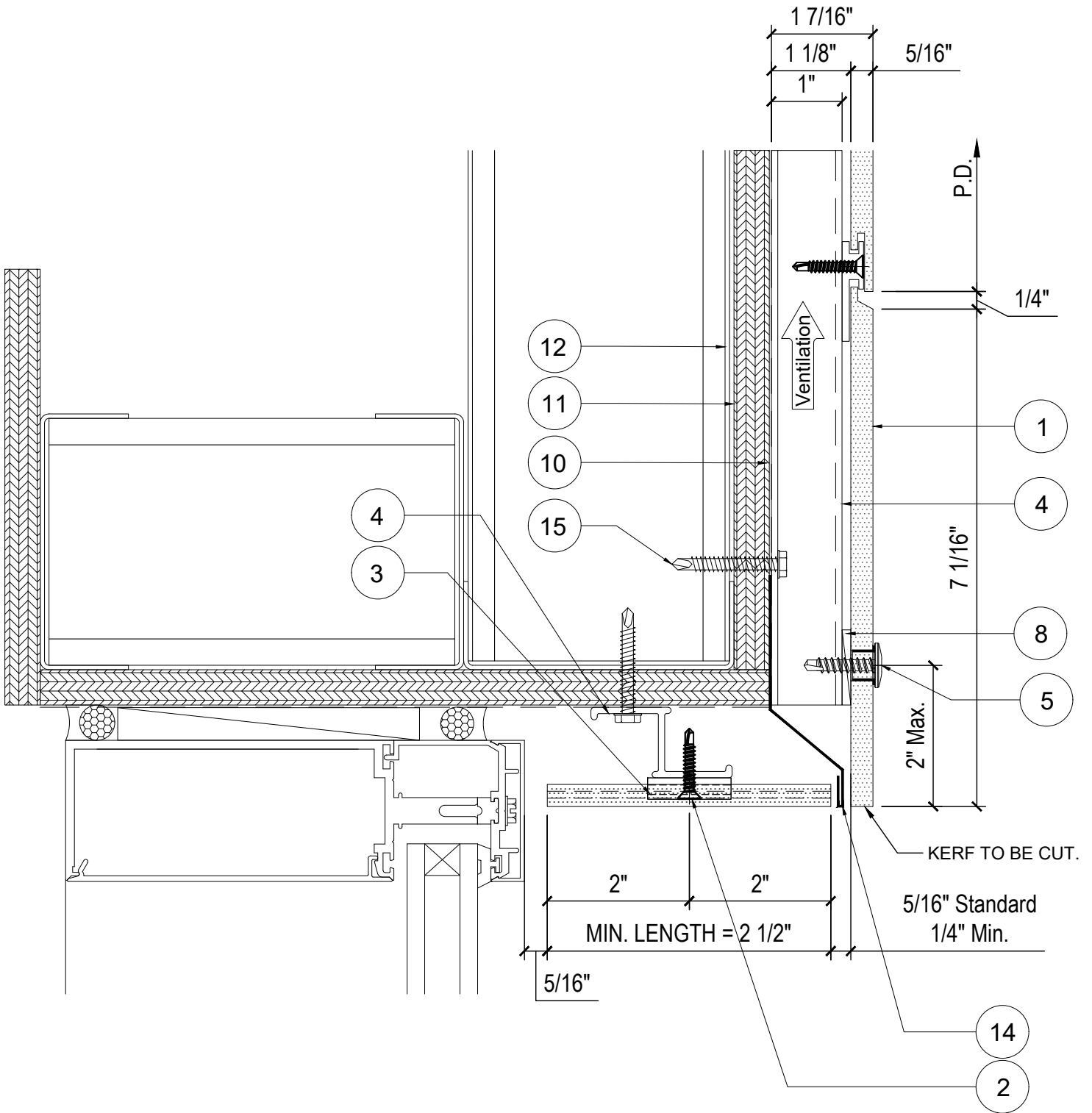

**EASYMEG**

**ABET LAMINATI**



STANDARD DETAIL CREATION

01/18/2023

REV.

ISSUANCE

DATE

DETAIL NAME:

**WINDOW HEAD  
 DETAIL (J2)**

DWG. BY: ACE

CHK. BY: ACE

PG. NO: 13 OF 28

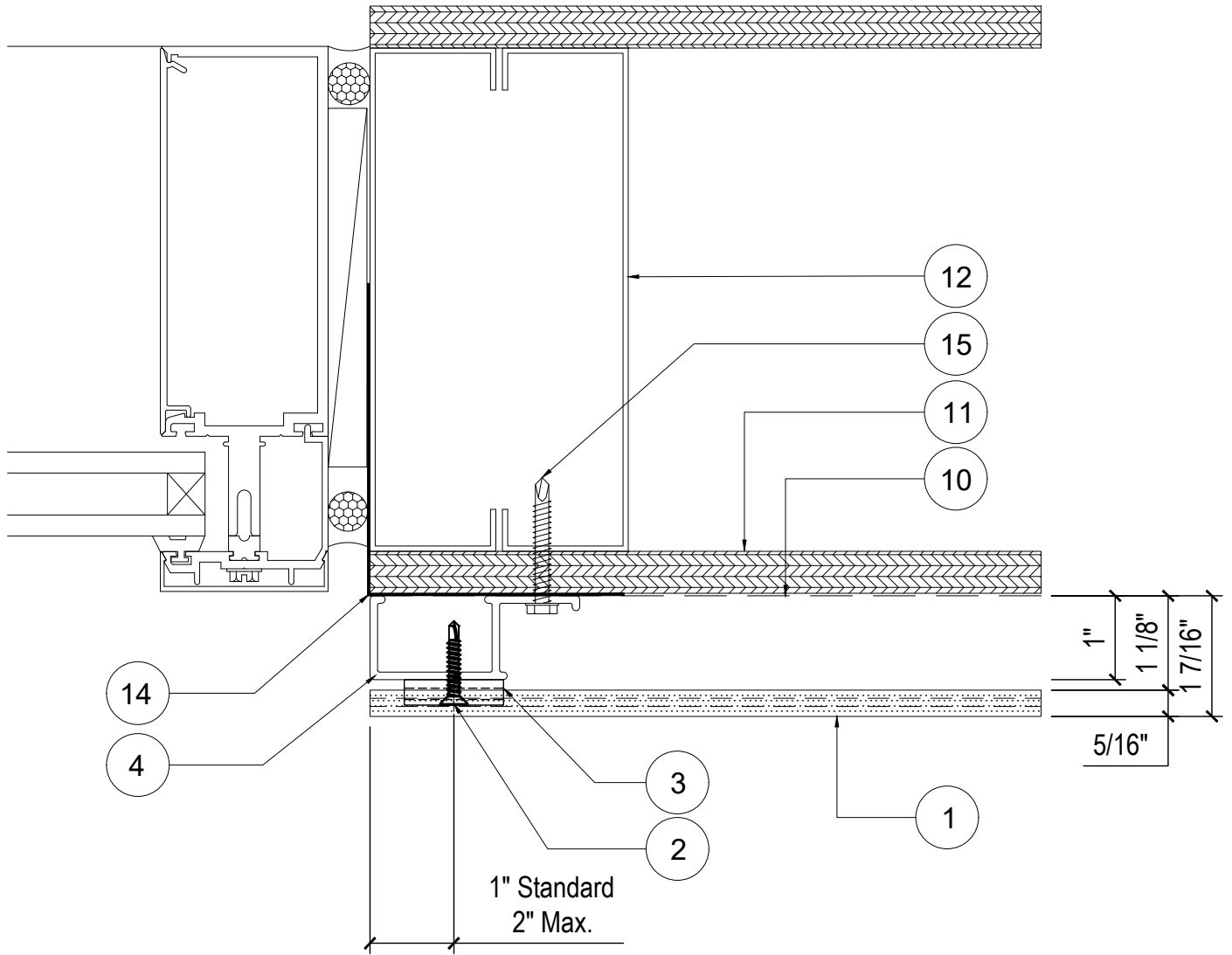

**EASYMEG**  
**ABET LAMINATI**



REV.

STANDARD DETAIL CREATION

ISSUANCE

01/18/2023

DATE

DETAIL NAME:

**WINDOW JAMB  
 DETAIL (K1)**

DWG. BY: ACE

CHK. BY: ACE

PG. NO: 14 OF 28

MIN LENGTH = 2 1/2" - 2" TO ALLOW FOR COVERAGE OF CLIP + 1/4" OVERAGE ON EACH SIDE  
 PANEL LENGTH > 4" 2 CLIPS ARE REQUIRED

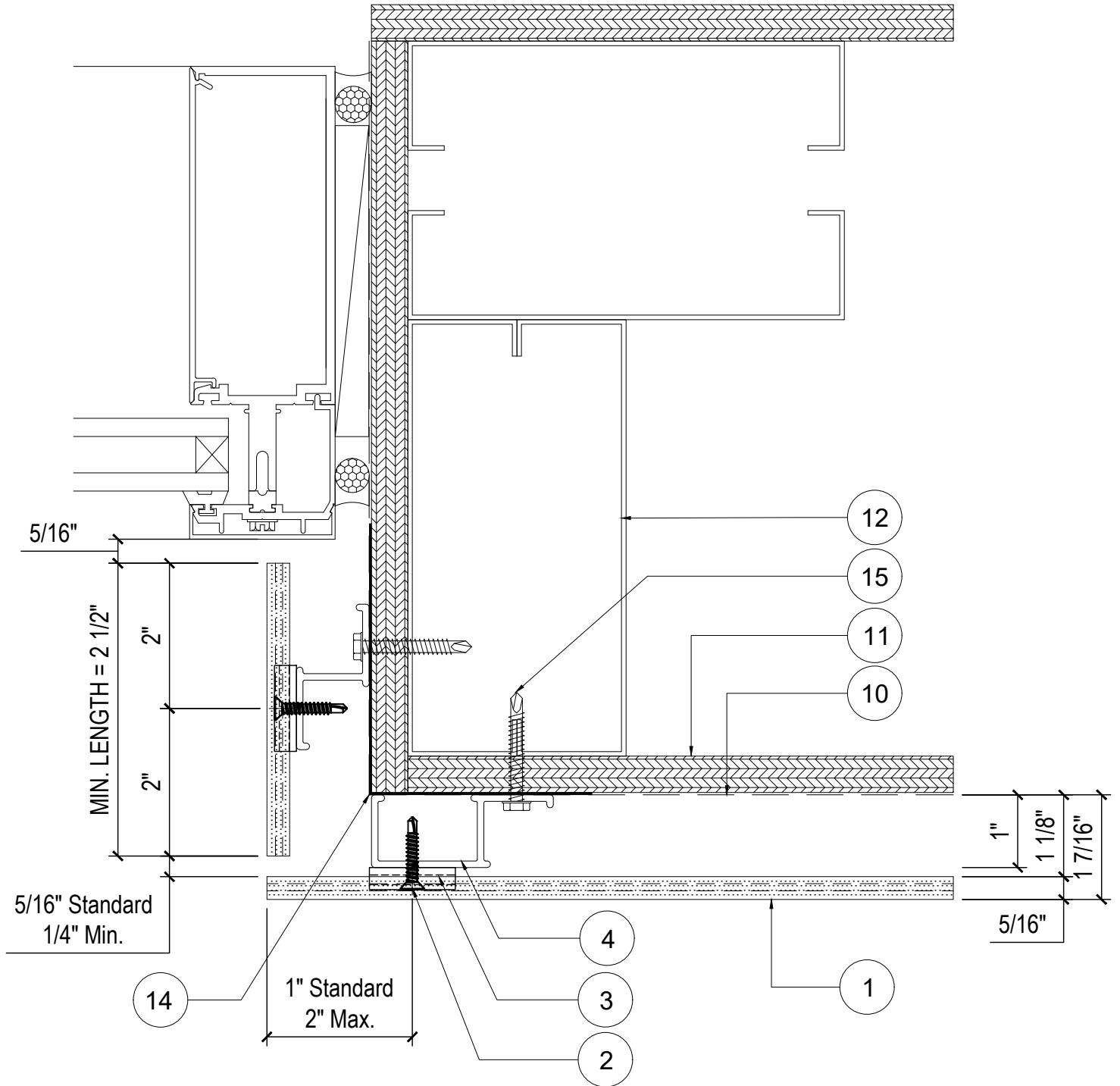

**EASYMEG**

**ABET LAMINATI**



STANDARD DETAIL CREATION

01/18/2023

REV.

ISSUANCE

DATE

DETAIL NAME:

WINDOW JAMB  
 DETAIL (K2)

DWG. BY: ACE

CHK. BY: ACE

PG. NO: 15 OF 28



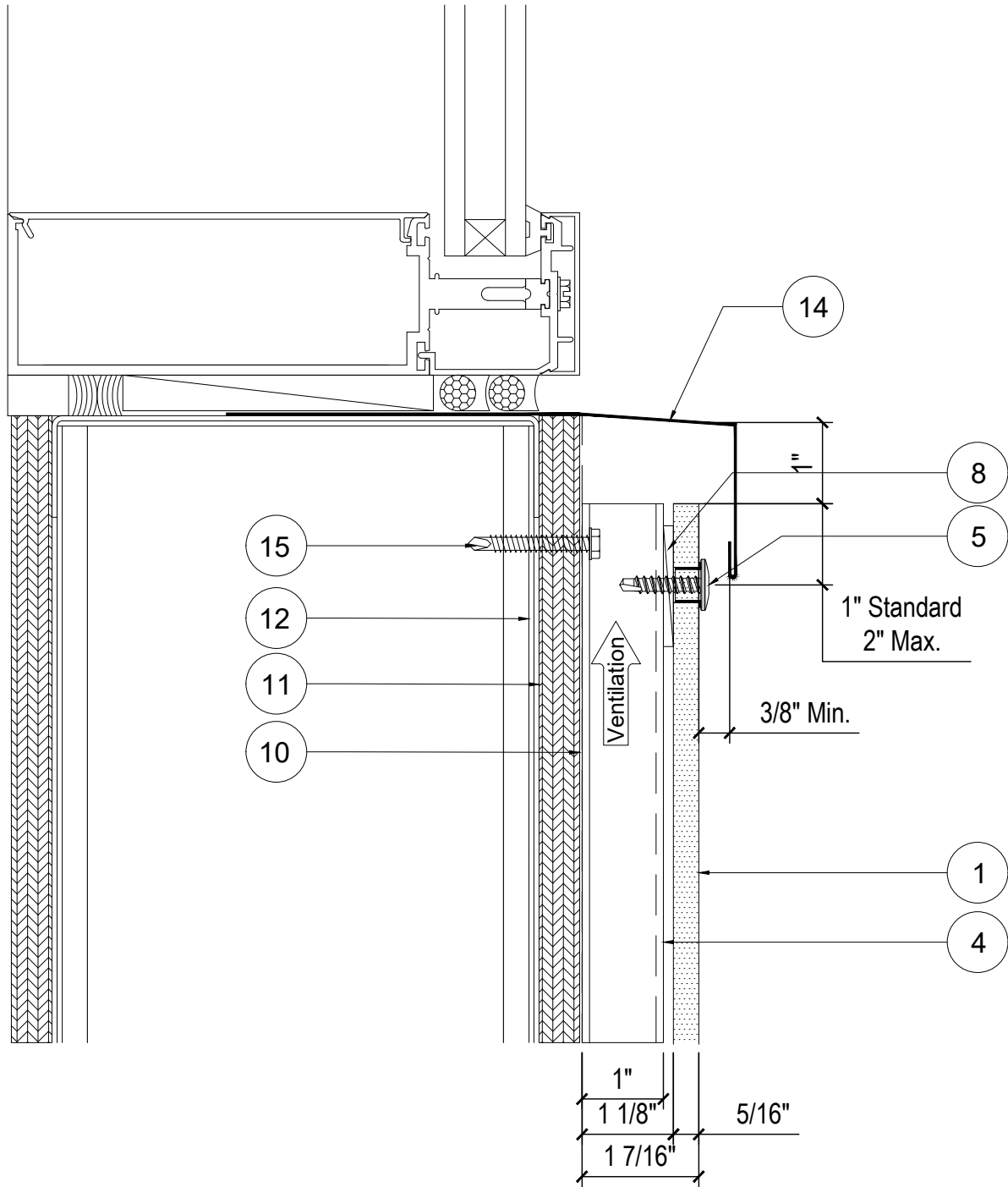

**EASYMEG**

**ABET LAMINATI**



STANDARD DETAIL CREATION

01/18/2023

REV.

ISSUANCE

DATE

DETAIL NAME:

**WINDOW SILL  
DETAIL (L)**

DWG. BY: ACE

CHK. BY: ACE

PG. NO: 16 OF 28

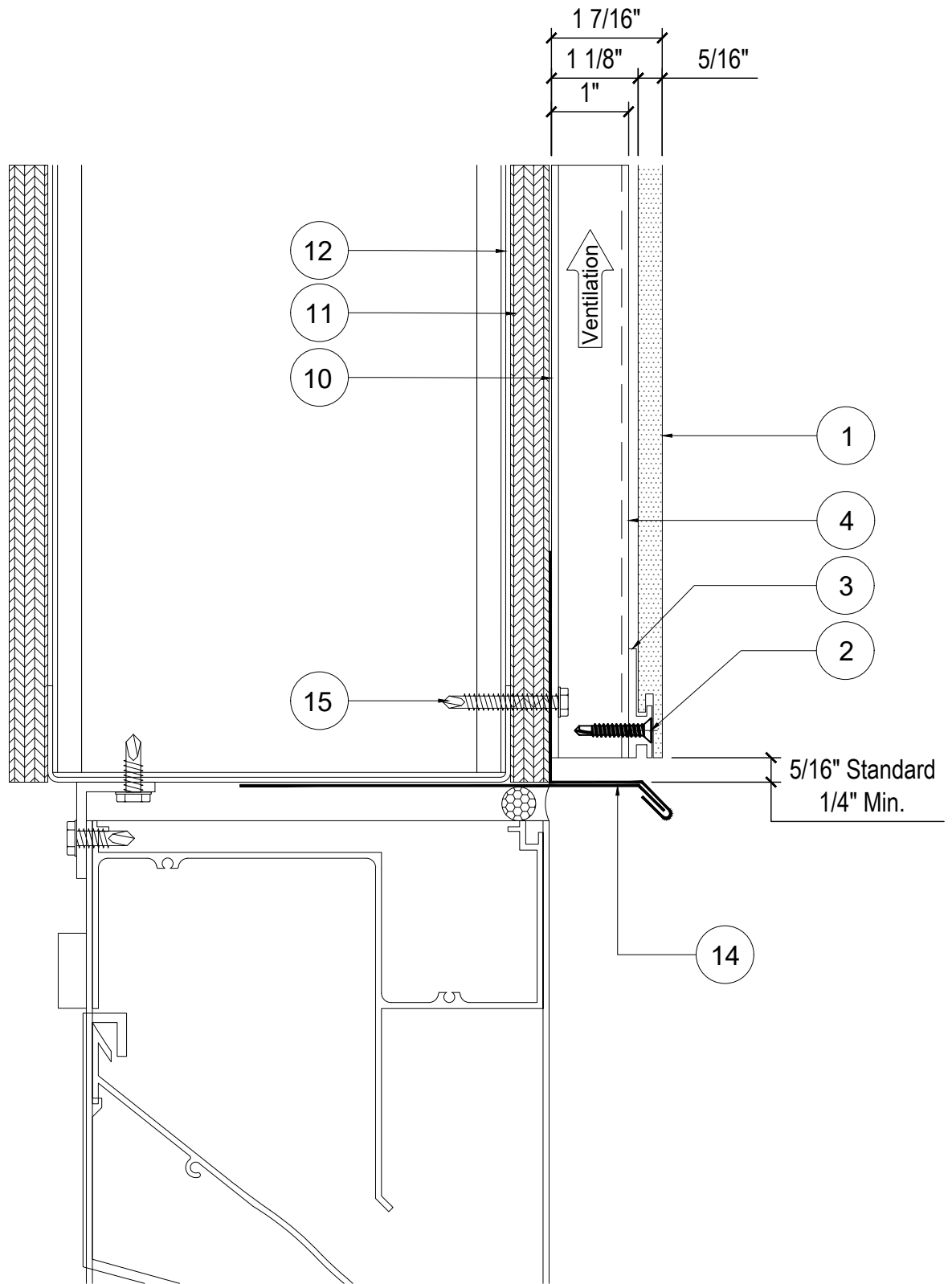

**EASYMEG**  
**ABET LAMINATI**



STANDARD DETAIL CREATION

01/18/2023

REV.

ISSUANCE

DATE

DETAIL NAME:

**LOUVER HEAD  
DETAIL (M)**

DWG. BY: ACE

CHK. BY: ACE

PG. NO: 17 OF 28

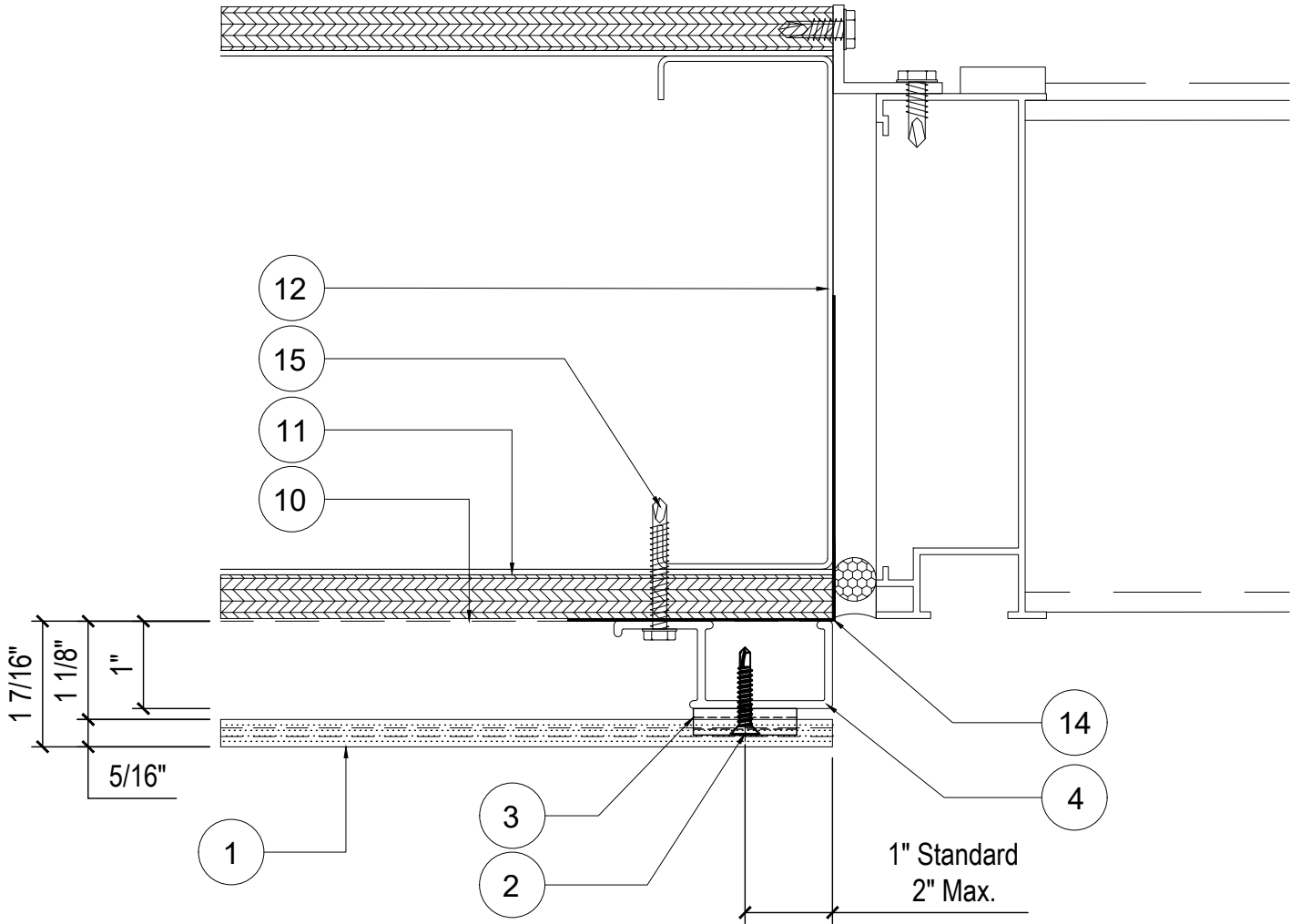

**EASYMEG**  
**ABET LAMINATI**

0  
 REV.

STANDARD DETAIL CREATION  
 ISSUANCE

01/18/2023  
 DATE

DETAIL NAME:  
**LOUVER JAMB  
 DETAIL (N)**  
 DWG. BY: ACE    CHK. BY: ACE    PG. NO: 18 OF 28

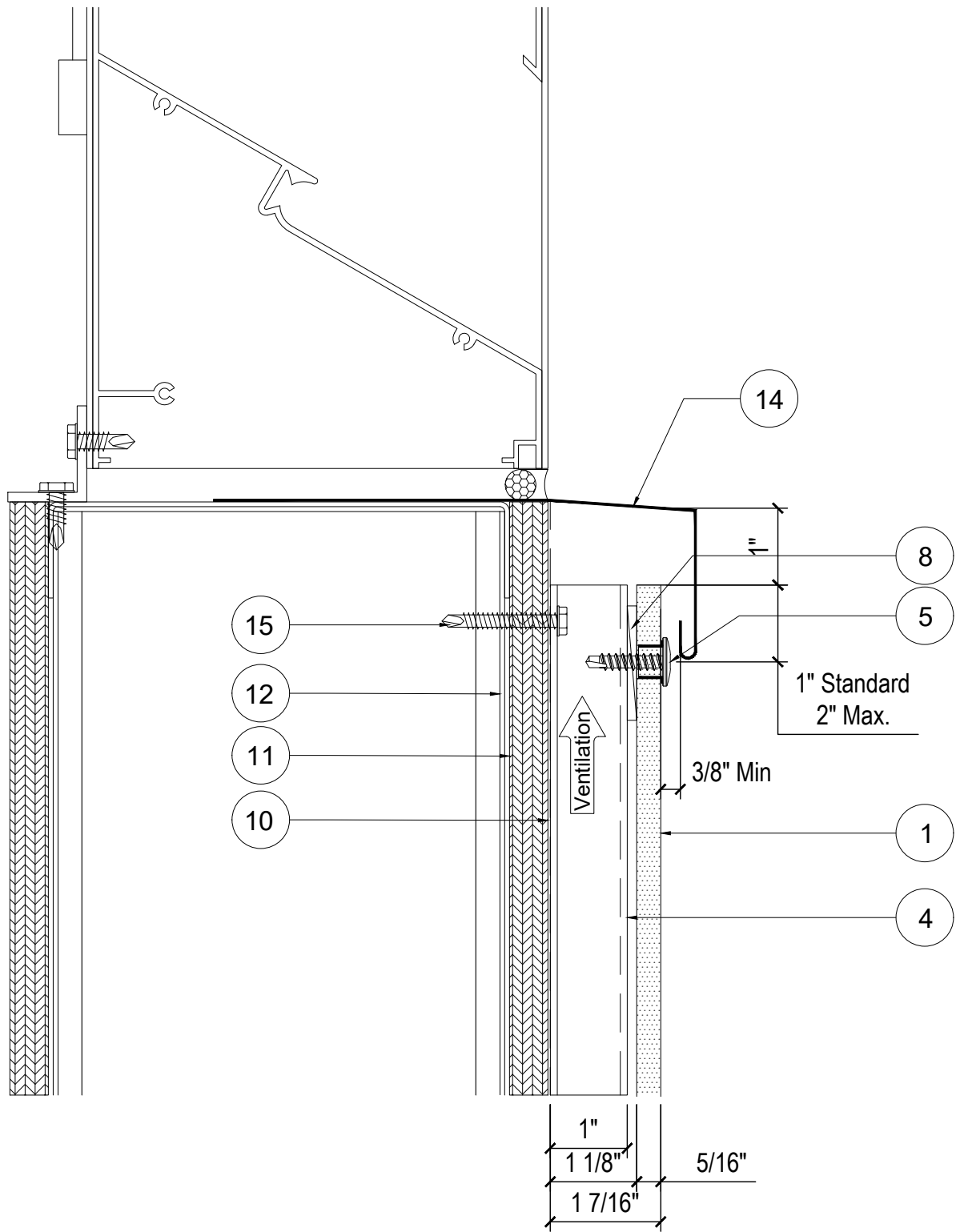

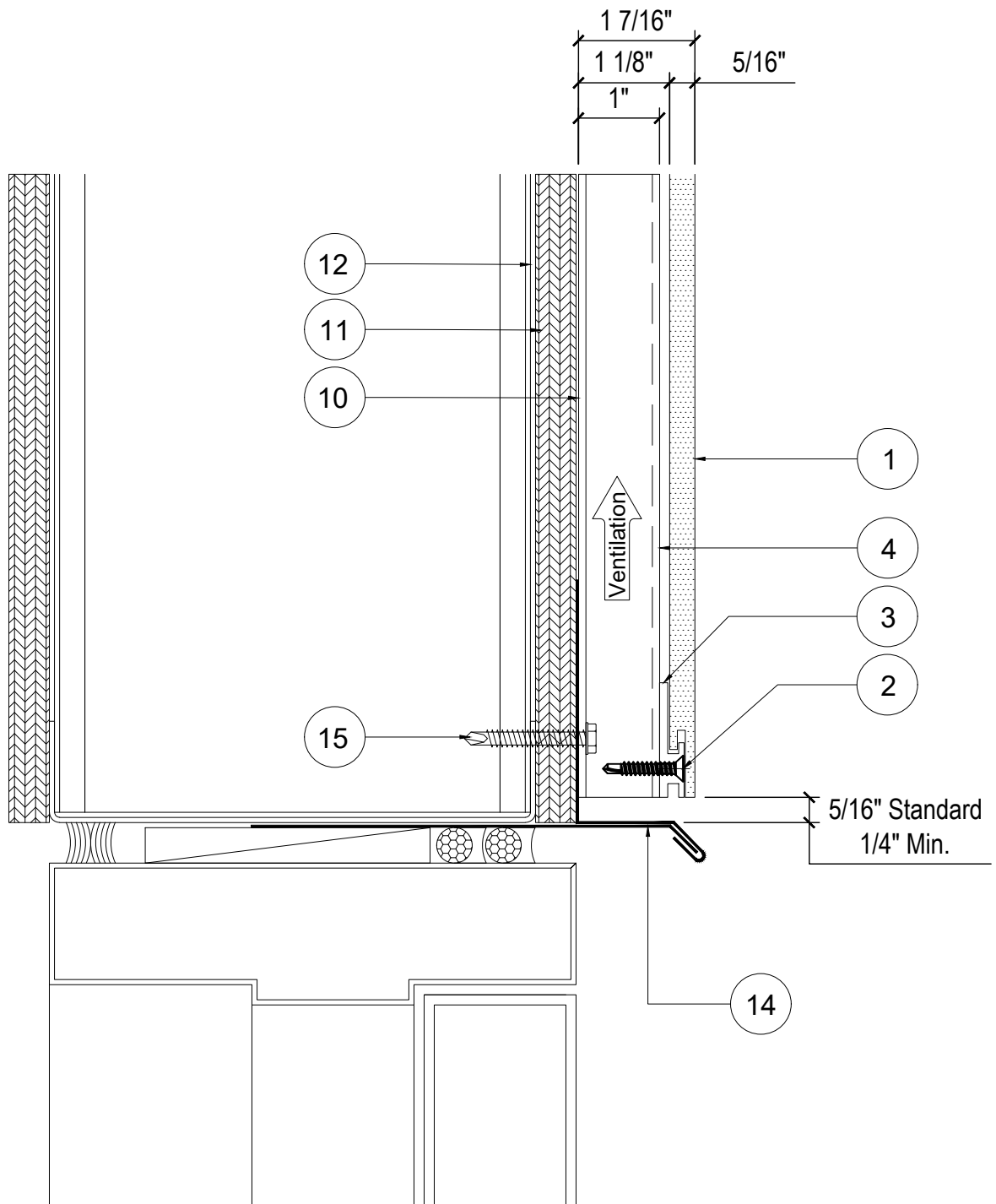

**EASYMEG**  
**ABET LAMINATI**



STANDARD DETAIL CREATION

01/18/2023

REV.

ISSUANCE

DATE

DETAIL NAME:

H.M. DOOR HEAD  
DETAIL (Q)

DWG. BY: ACE

CHK. BY: ACE

PG. NO: 20 OF 28

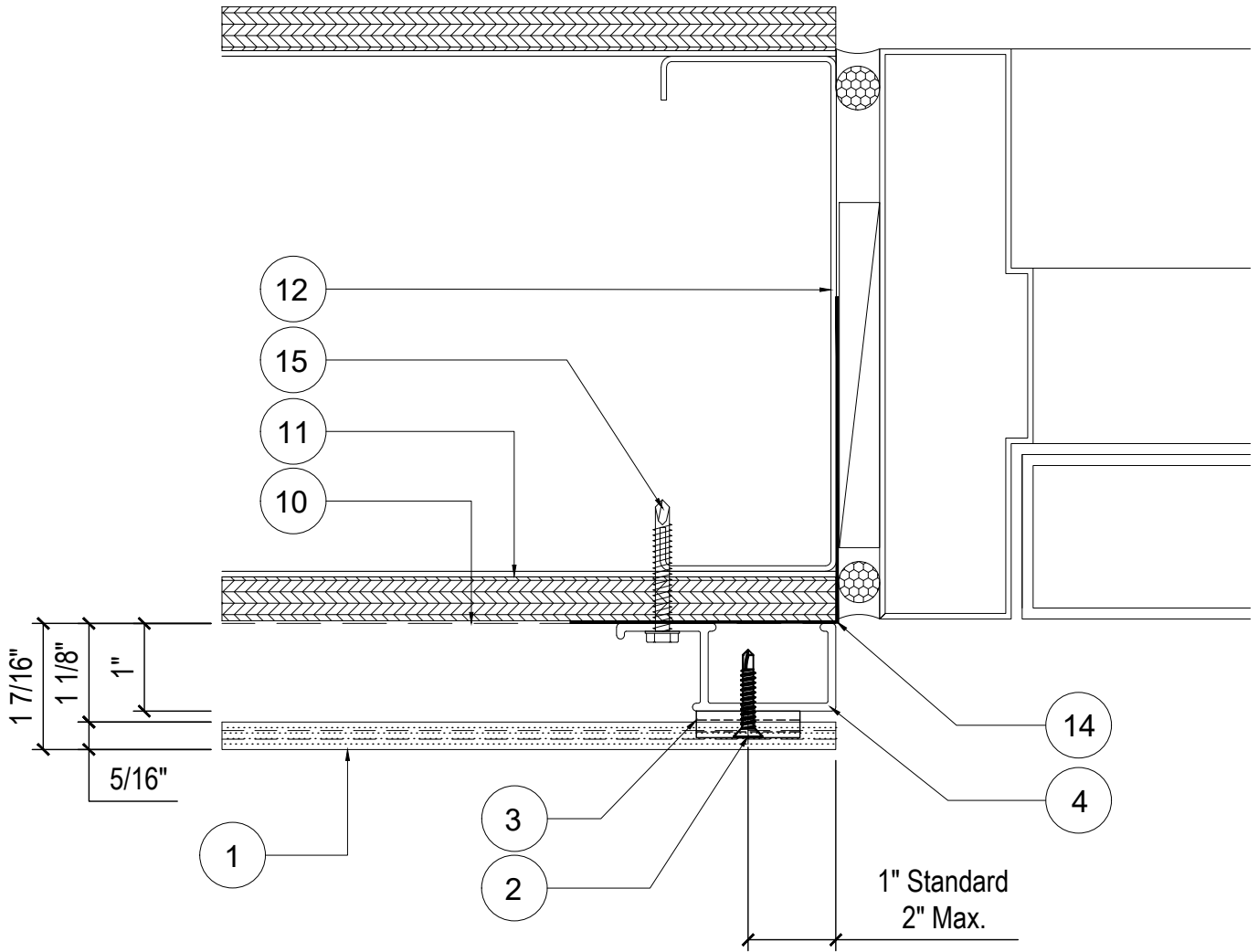

**EASYMEG**

**ABET LAMINATI**



STANDARD DETAIL CREATION

01/18/2023

REV.

ISSUANCE

DATE

DETAIL NAME:

**H.M. DOOR JAMB  
DETAIL (R)**

DWG. BY: ACE

CHK. BY: ACE

PG. NO: 21 OF 28

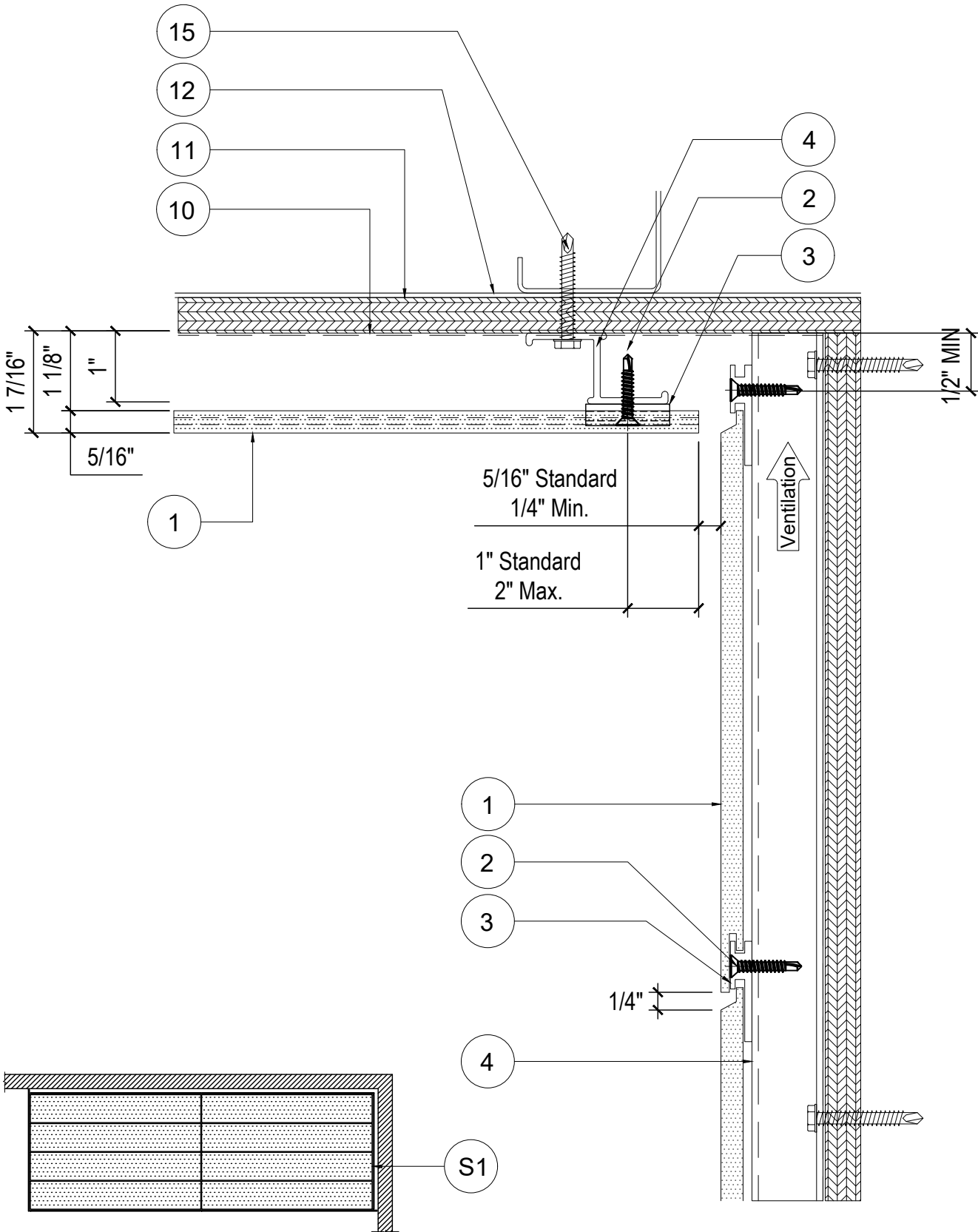

REFLECTED CEILING PLAN



STANDARD DETAIL CREATION

01/18/2023

REV.

ISSUANCE

DATE

DETAIL NAME:

PANEL SOFFIT TRANSITION  
DETAIL (S1)

DWG. BY: ACE

CHK. BY: ACE

PG. NO: 22 OF 28

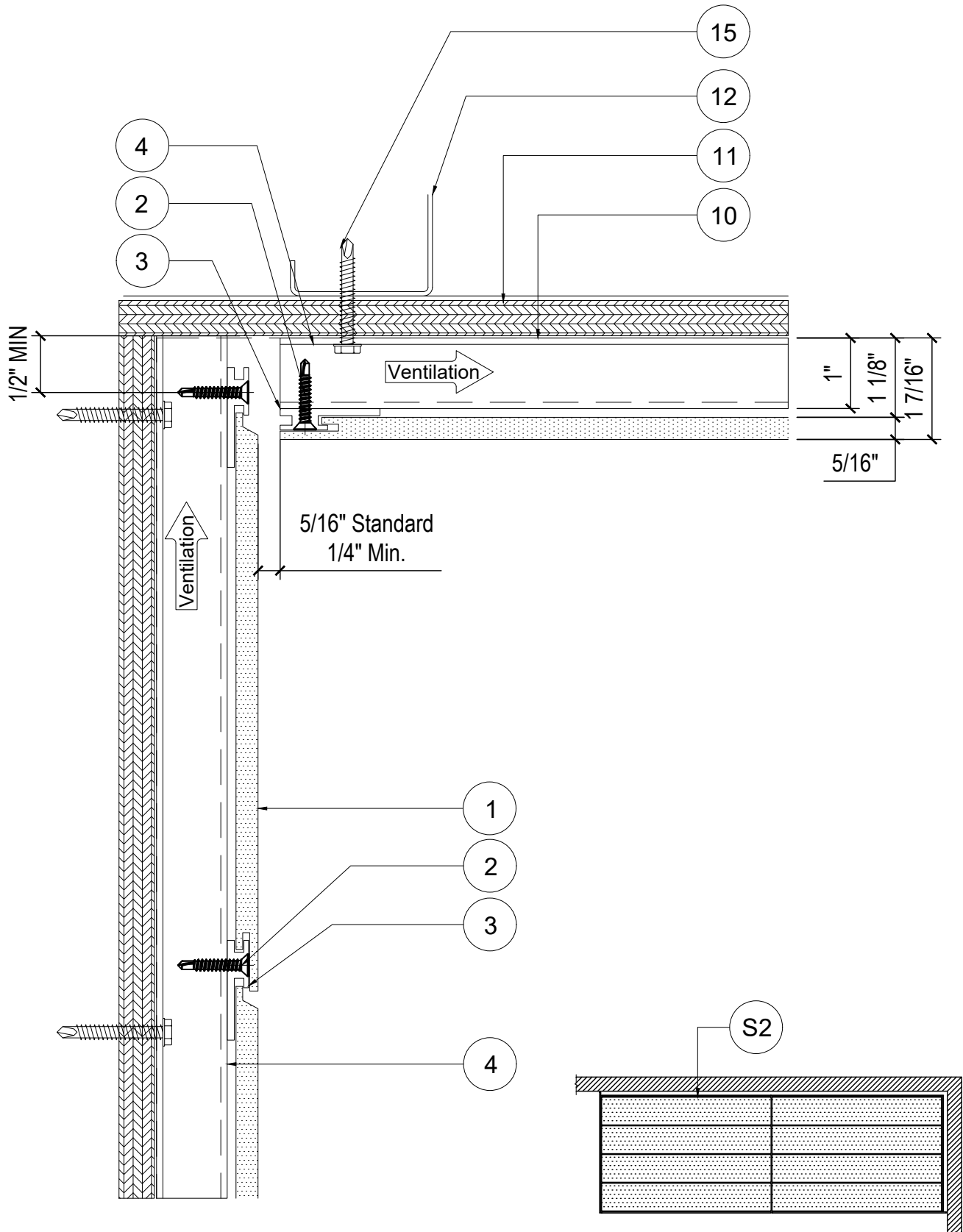

REFLECTED CEILING PLAN

**EASYMEG**

**ABET LAMINATI**



STANDARD DETAIL CREATION

01/18/2023

REV.

ISSUANCE

DATE

DETAIL NAME:

**PANEL SOFFIT TRANSITION  
DETAIL (S2)**

DWG. BY: ACE

CHK. BY: ACE

PG. NO: 23 OF 28



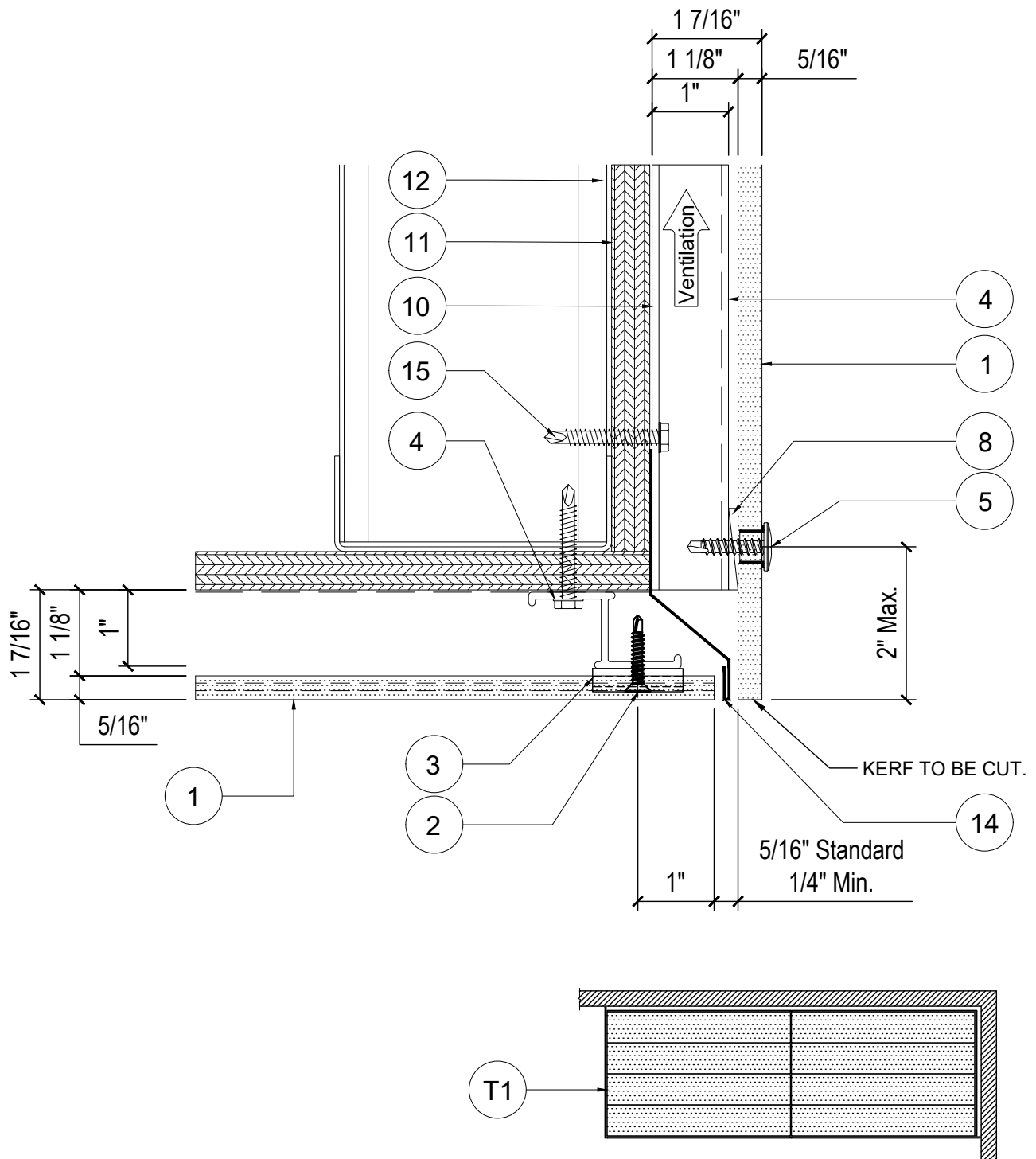

REFLECTED CEILING PLAN

**EASYMEG**

**ABET LAMINATI**



STANDARD DETAIL CREATION

01/18/2023

REV.

ISSUANCE

DATE

DETAIL NAME:

PANEL SOFFIT TRANSITION  
DETAIL (T1)

DWG. BY: ACE

CHK. BY: ACE

PG. NO: 24 OF 28

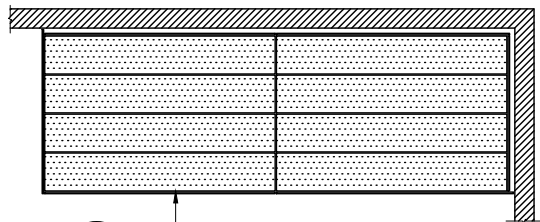
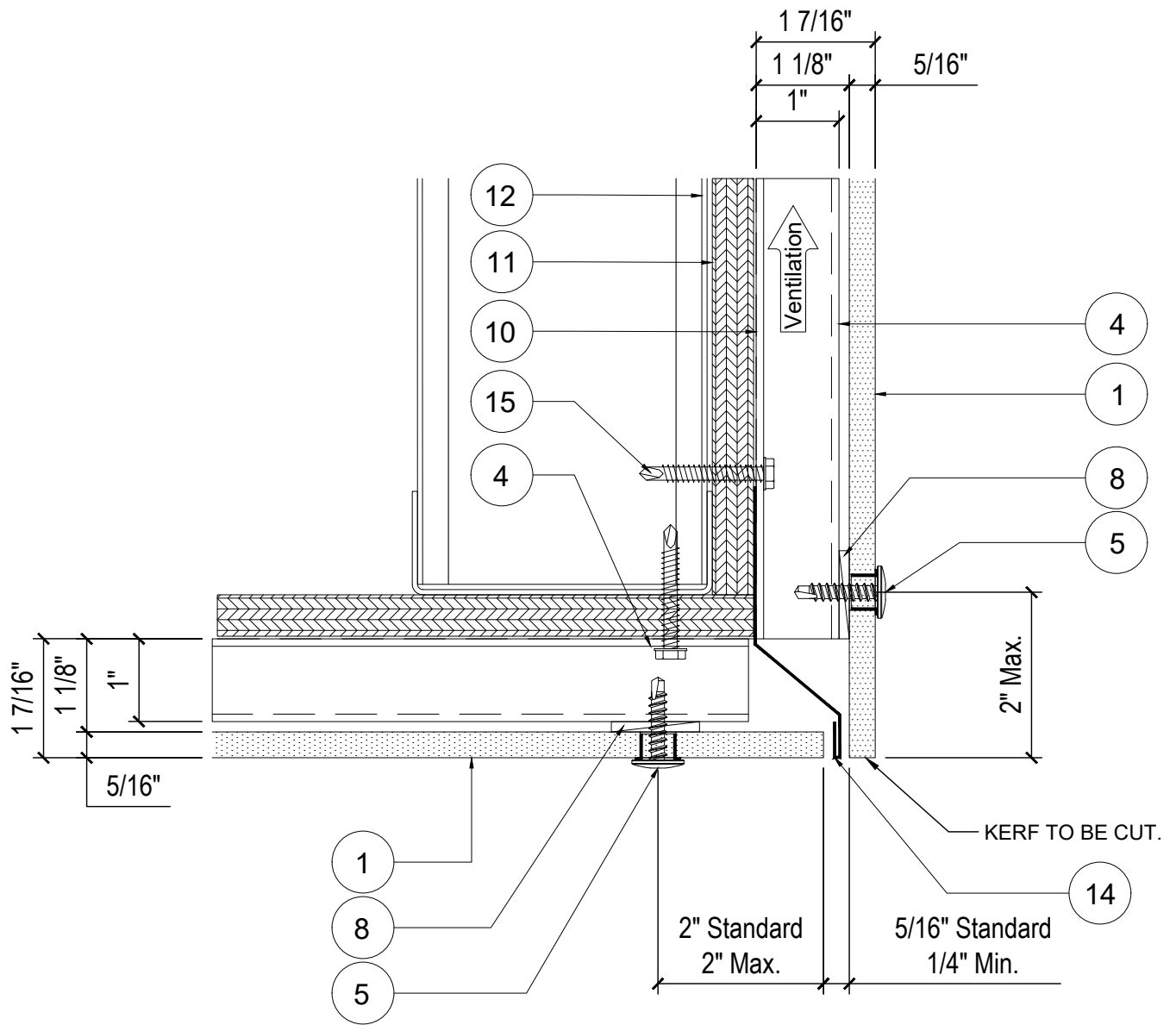

REFLECTED CEILING PLAN

**EASYMEG**

**ABET LAMINATI**



STANDARD DETAIL CREATION

01/18/2023

REV.

ISSUANCE

DATE

DETAIL NAME:

**PANEL SOFFIT TRANSITION  
DETAIL (T2)**

DWG. BY: ACE

CHK. BY: ACE

PG. NO: 25 OF 28

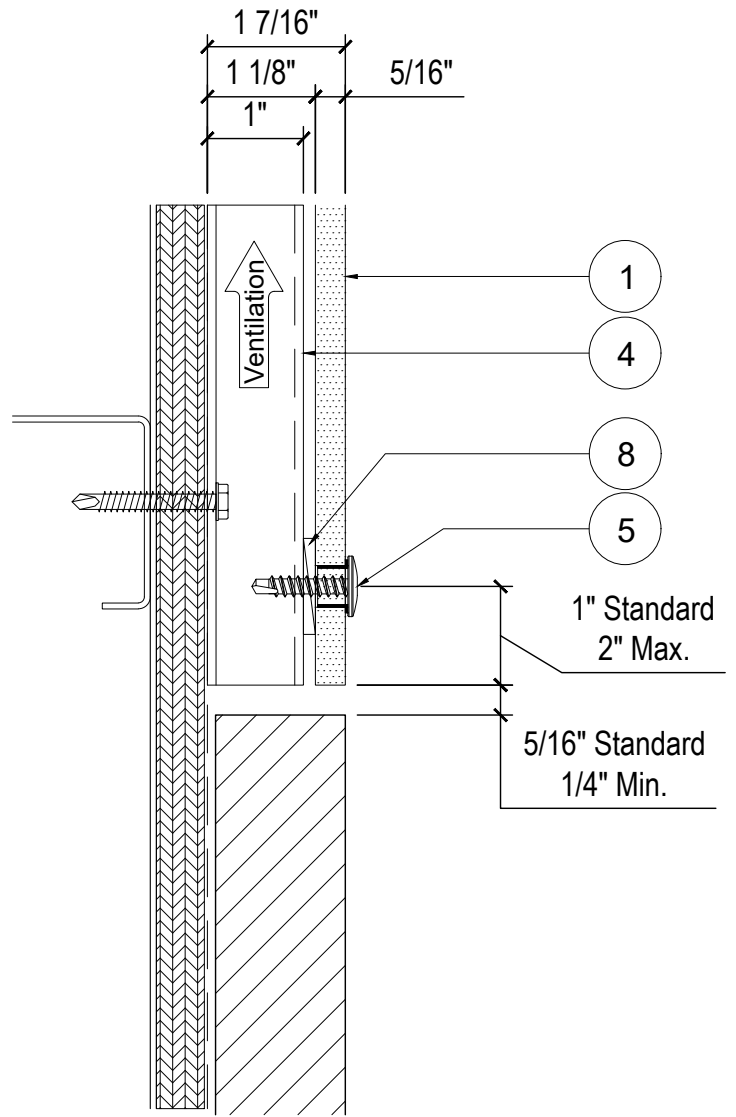
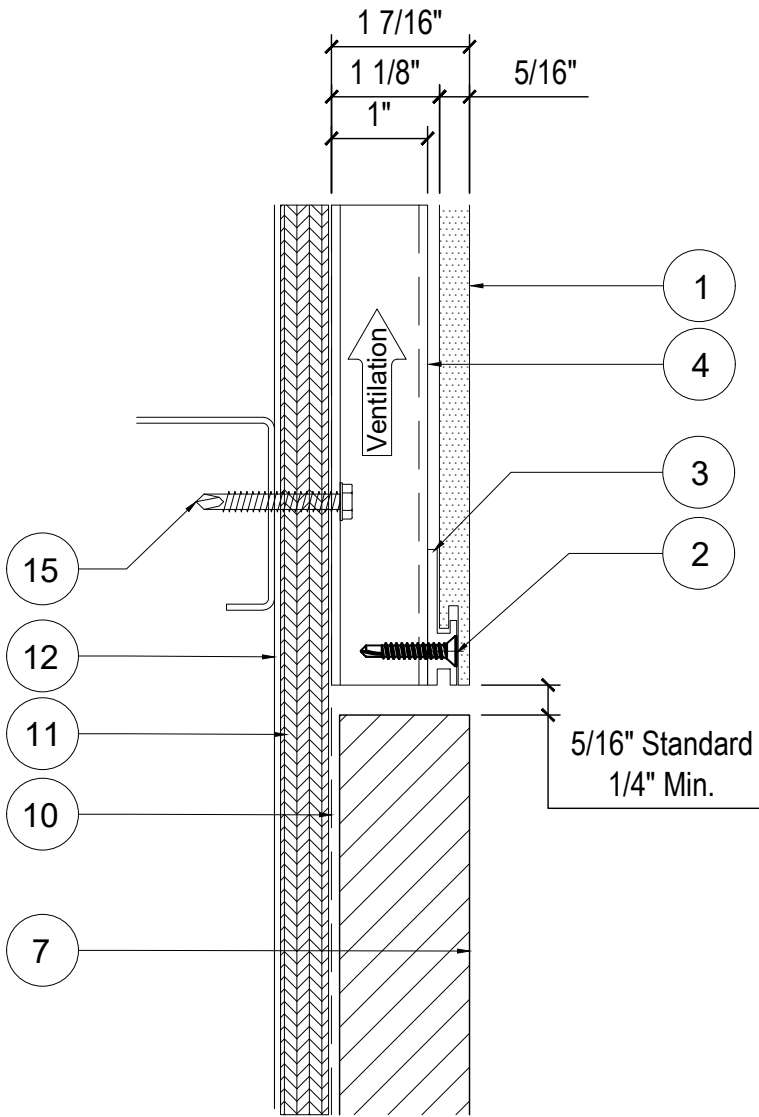

**EASYMEG**

**ABET LAMINATI**



STANDARD DETAIL CREATION

01/18/2023

REV.

ISSUANCE

DATE

DETAIL NAME:

**HORIZONTAL TRANSITION  
DETAIL @ ARCH. PANEL (U)**

DWG. BY: ACE

CHK. BY: ACE

PG. NO: 26 OF 28

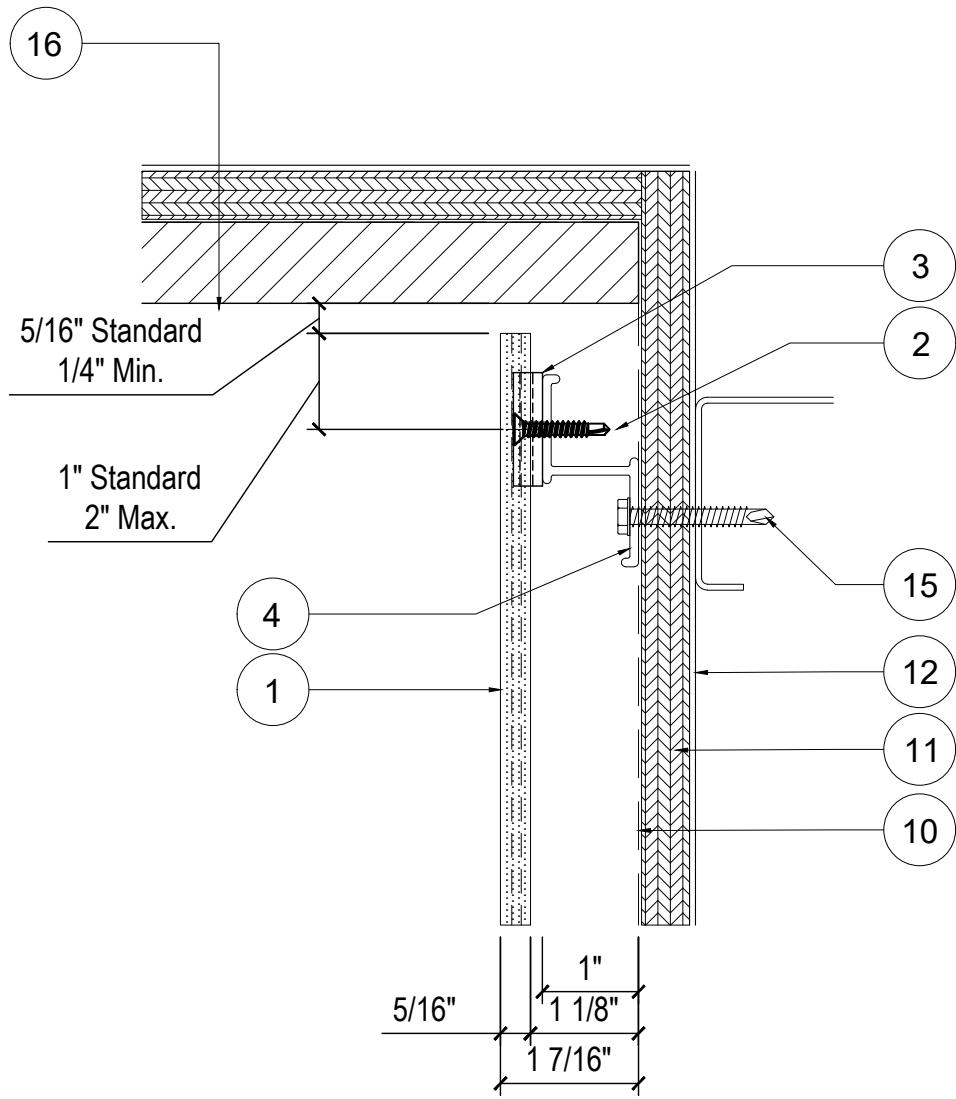

**EASYMEG**  
**ABET LAMINATI**

△  
 0

STANDARD DETAIL CREATION  
 ISSUANCE

01/18/2023  
 DATE

DETAIL NAME:  
**VERTICAL TRANSITION  
 DETAIL @ ARCH. PANEL (V)**

DWG. BY: ACE    CHK. BY: ACE    PG. NO: 27 OF 28

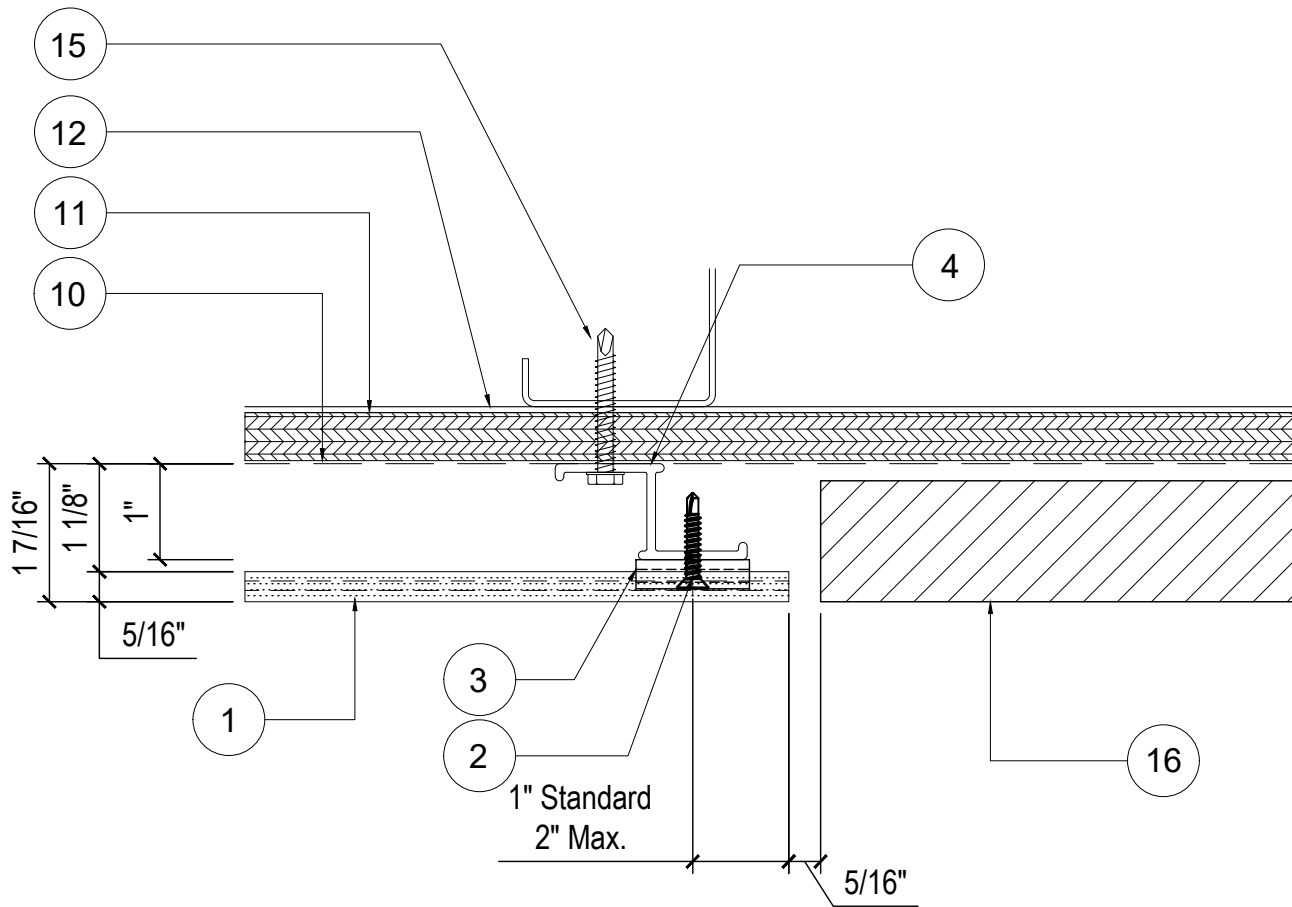

**EASYMEG**

**ABET LAMINATI**



STANDARD DETAIL CREATION

01/18/2023

REV.

ISSUANCE

DATE

DETAIL NAME:

**VERTICAL TRANSITION  
DETAIL @ ARCH. PANEL (W)**

DWG. BY: ACE

CHK. BY: ACE

PG. NO: 28 OF 28